



Special class on

Simple Mechanism Part I

Apr 24, 2020 • Alok Jha



 **plus**
Subscription



ALOK JHA SIR

GATE | ESE (ME)



4 Times

GATE Top Ranker
M.Tech IIT (ISM) Dhanbad



GATE/ESE:

8 Years Teaching
Experience



Subjects Taken:

Theory of Machines,
Strength of Materials,
Machine Design, and
Engineering Mechanics



Use My Referral

Code: **"ALOKLIVE"** to **Get 10% Off**
on Unacademy **PLUS** Subscription



UNACADEMY PLUS

LEARN ONLINE **LIVE** FROM
— INDIA'S BEST EDUCATORS —



Devendra Singh Negi



Pallav Gour



Sarvesh Srivastava



Alok Jha



Viresh Manocha



Apuroop Rao



Amit Dixit



Vishal Sharma

Syllabus

- **Simple mechanism**
- **Velocity & Acceleration analysis**
- **Toothed gear**
- **Gear train**
- **Governor**
- **Flywheel**
- **Kinematic analysis of single slider crank chain mechanism**
- **Dynamics analysis of single slider crank chain mechanism**
- **Gyroscope**
- **Balancing of masses**
- **Vibration**
- **Cam & follower**

Very Important topics in GATE

- **Simple machine (theory / numerical)**
- **Gear train (theory / numerical)**
- **Flywheel (numerical)**
- **Critical speed of shaft(vibration)**
- **Natural vibration (conceptual questions)**

GATE 2021 TOM SYLLABUS

Theory of Machines: Displacement, velocity and acceleration analysis of plane mechanisms; dynamic analysis of linkages; cams; gears and gear trains; flywheels and governors; balancing of reciprocating and rotating masses; gyroscope.

Vibrations: Free and forced vibration of single degree of freedom systems, effect of damping; vibration isolation; resonance; critical speeds of shafts.

• Books :-

- ✓ SS Rattan
- ✓ Thomas Bevan
- ✓ Joseph E. Shigley
- ✓ Class Notes

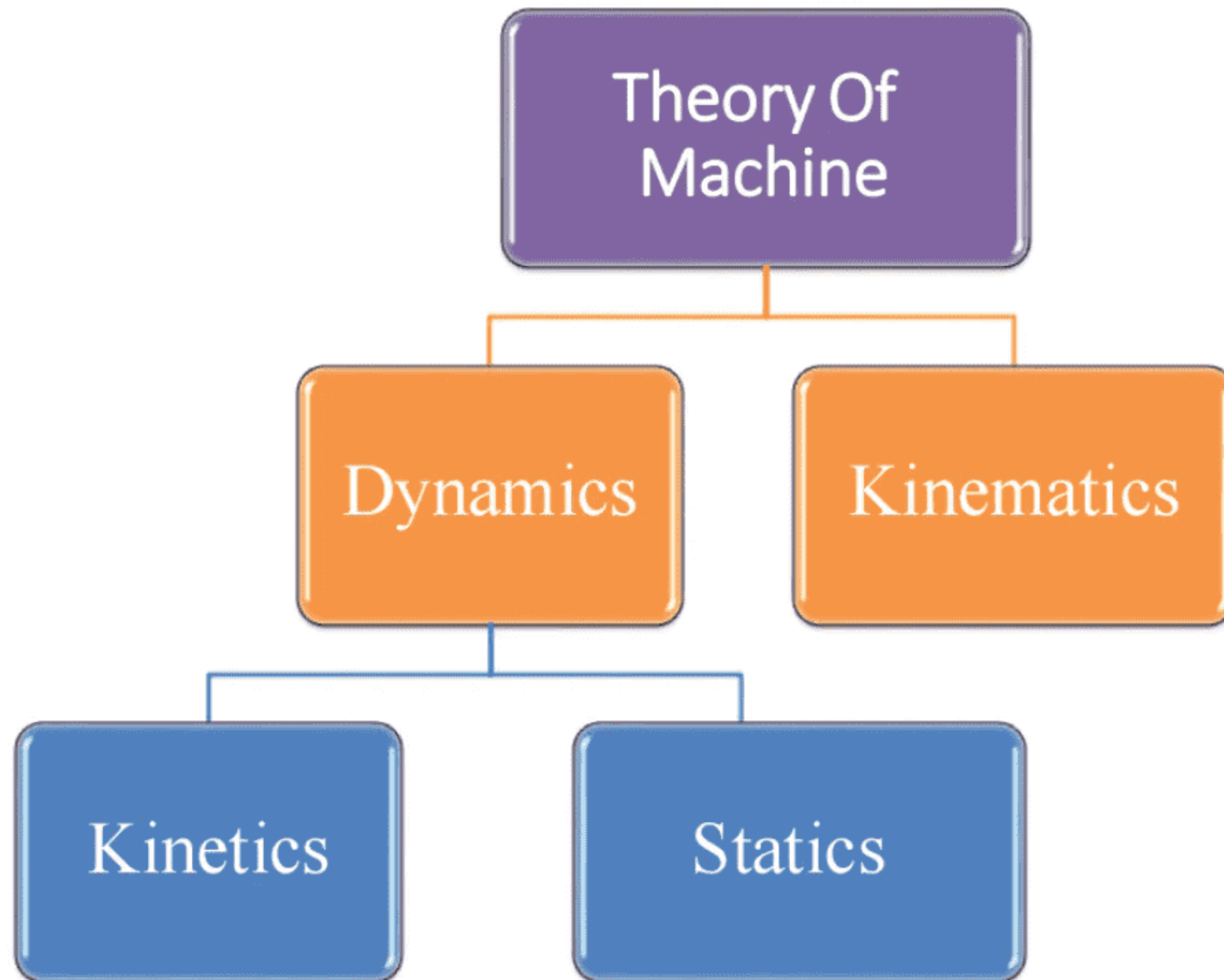

STATICS :

- It deals with the study the forces acting on machine in rest condition.

DYNAMICS :

- It deals with the study the forces acting on various parts of a machine or also we can say that study of motion with respect to force.

KINEMATICS :

- It is the study of motion, quite apart from the forces which produce that motion.
- Study of motion without considering force
- It is the study of position, displacement, rotation, speed, velocity and acceleration.

KINETICS :

- It is the study of inertia force which arises due to combined effect.

CHAPTER-1



SIMPLE MACHINE

SIMPLE MACHINE

□ WHAT IS MACHINE ?





Chatur Ramalingam : Sir, Machines are any combination of bodies so connected that their relative motions are constrained, and by which means force and motion may be transmitted and modified, as a screw and its nut, or a lever arranged to turn about a fulcrum or a pulley about its pivot. especially, a construction, more or less complex, consisting of a combination of moving parts or simple mechanical elements, as wheels, levers, cams etc.

Same thing, just in simple language ;



- **CHANCHAD:** "A machine is anything that reduces human effort. Anything that simplifies work, or saves time, is a machine. It's a warm day, press a button, get a blast of air - **the fan... A machine!** Speak to a friend miles away. **The telephone... A machine!** Compute millions in seconds. **The calculator... A machine!** We're surrounded by machines.

CONCLUSION OF THE STORY IS :-

- ✓ **Which reduce human effort.**
Example- Fan is a machine



Link
or
Part
or
Element

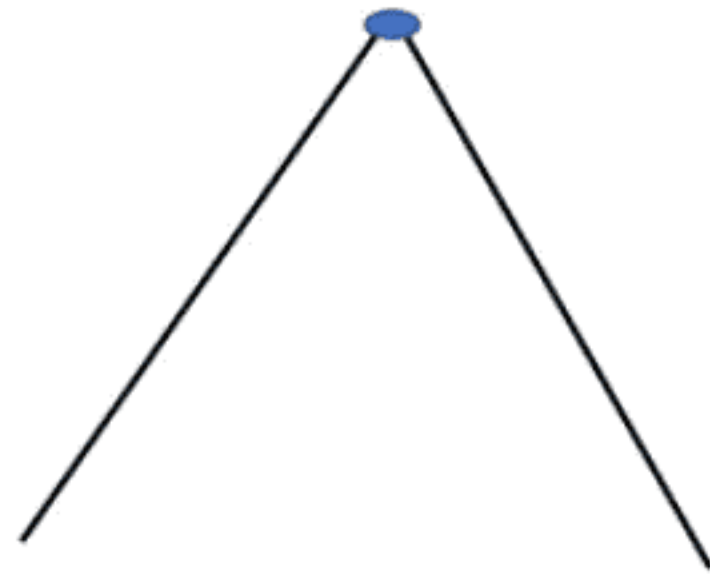

Pair

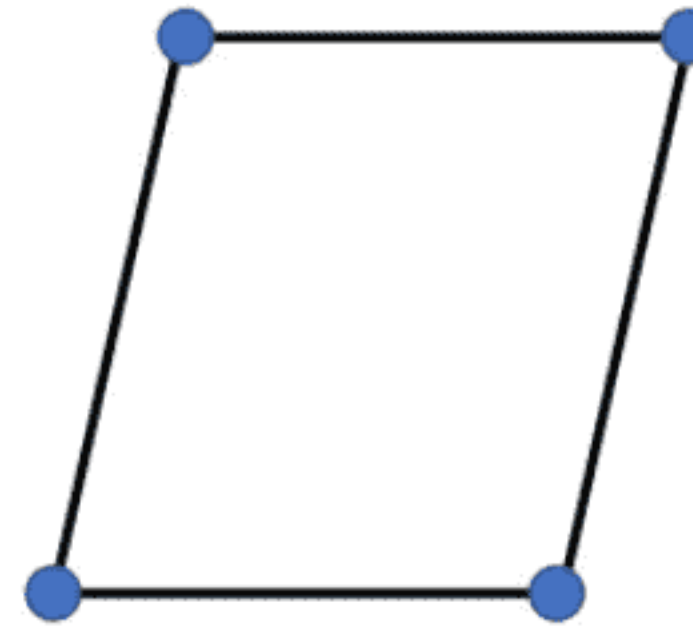

Chain

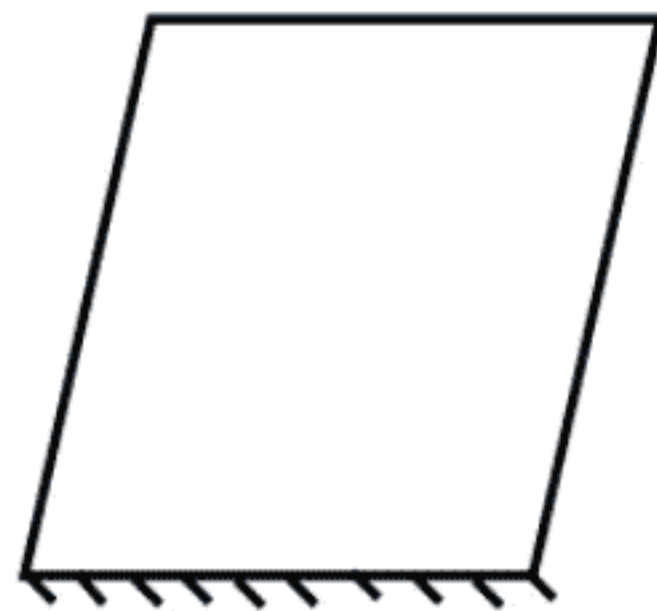

Mechanism

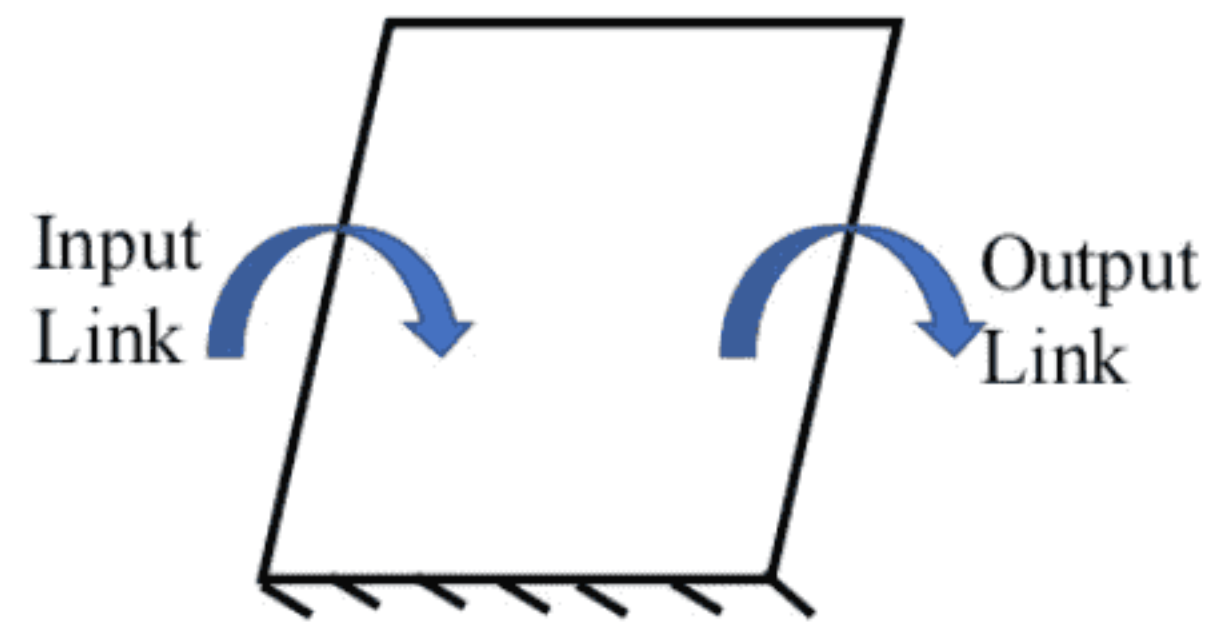

Machine

Now lets discuss about machine-

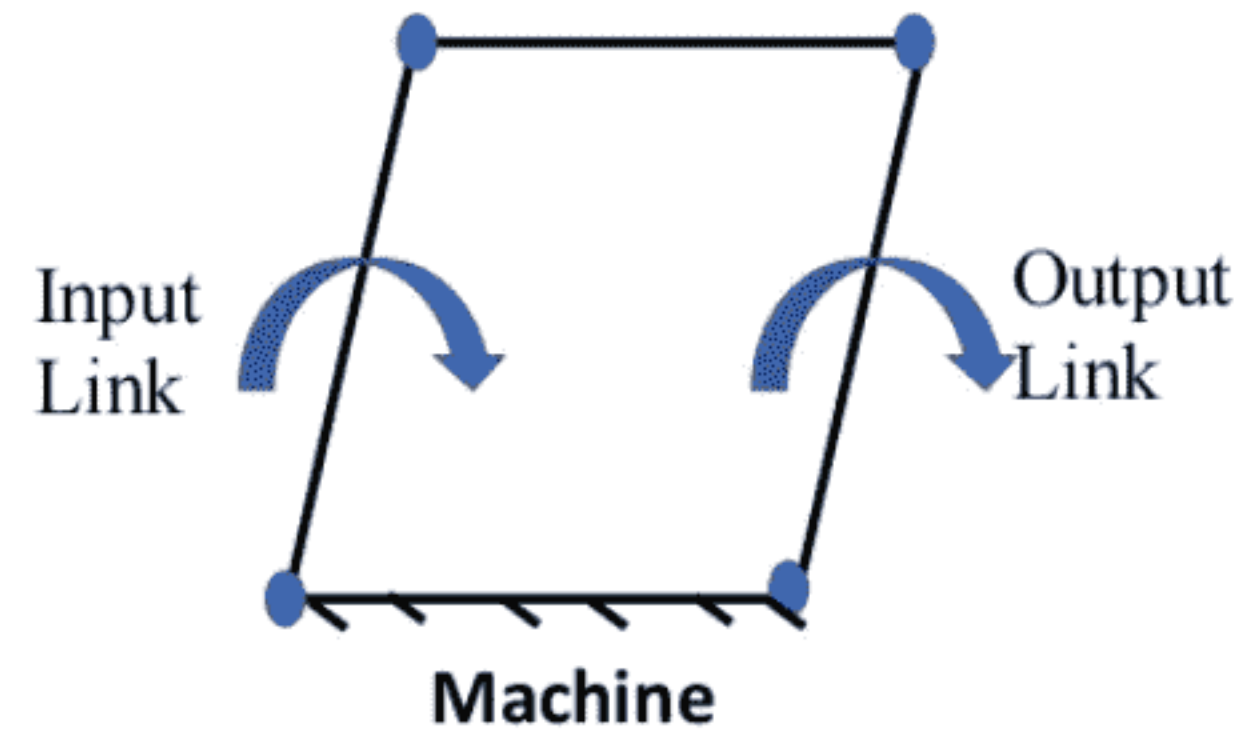

CONSTRAINED MOTIONS

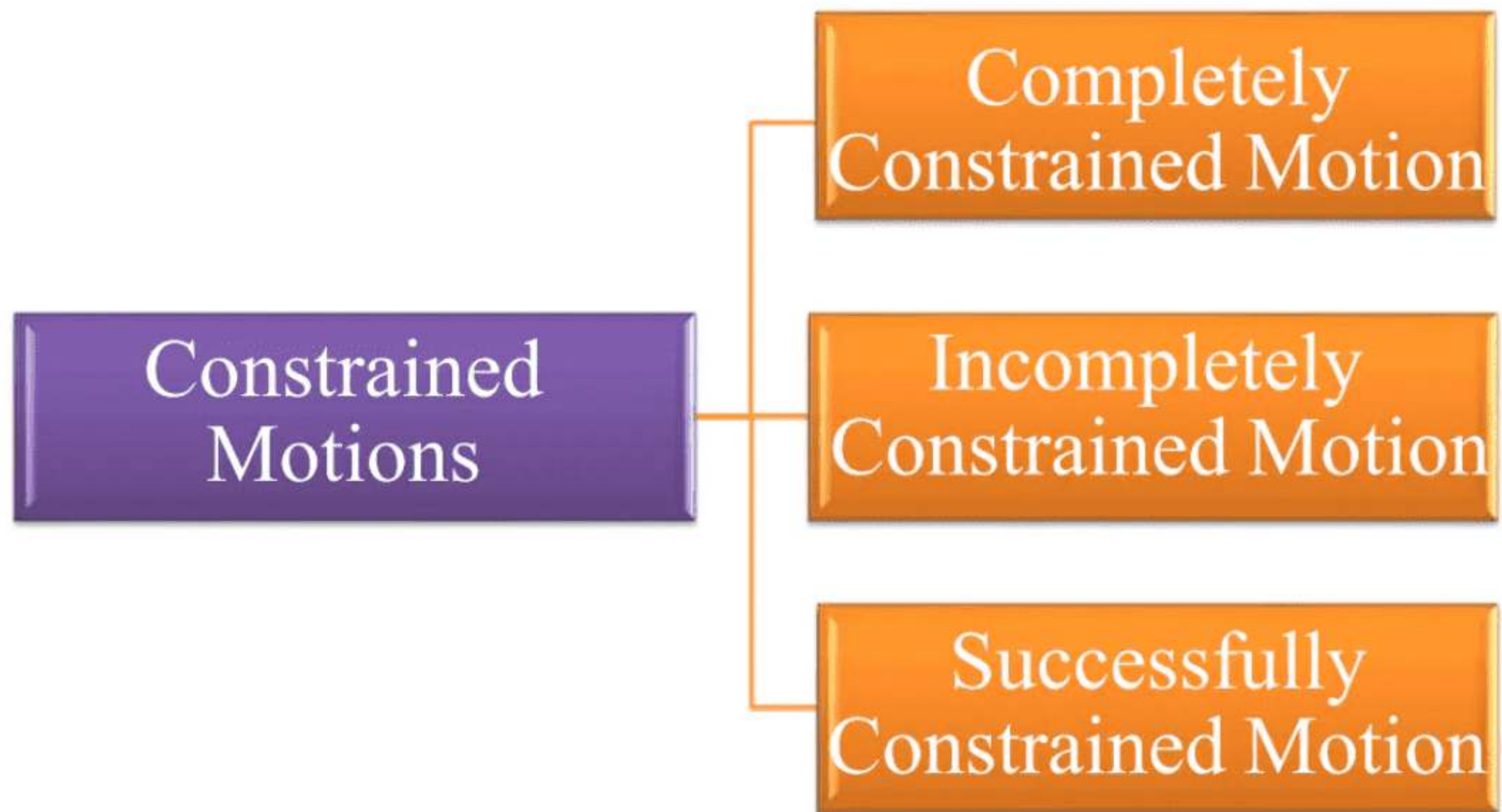

- Completely Constrained Motion

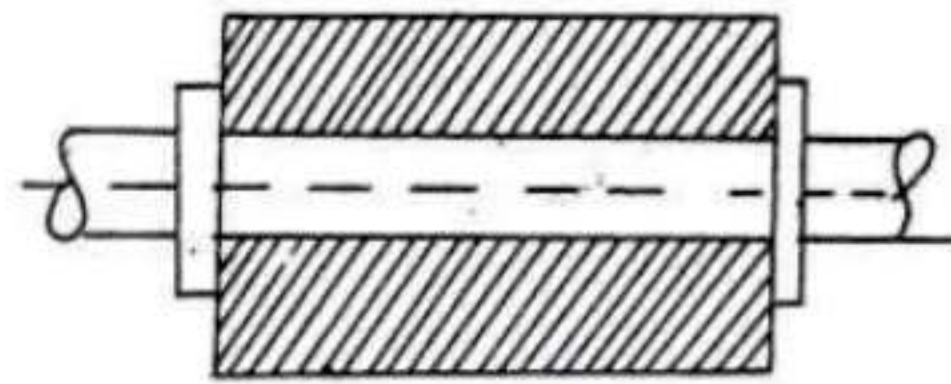
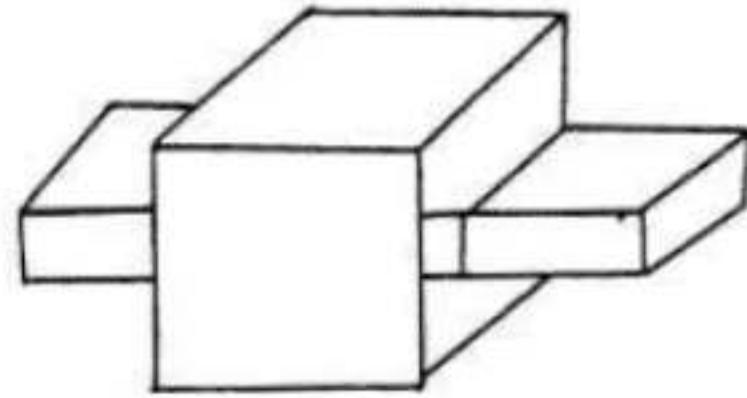

- Incomplete constrained motion

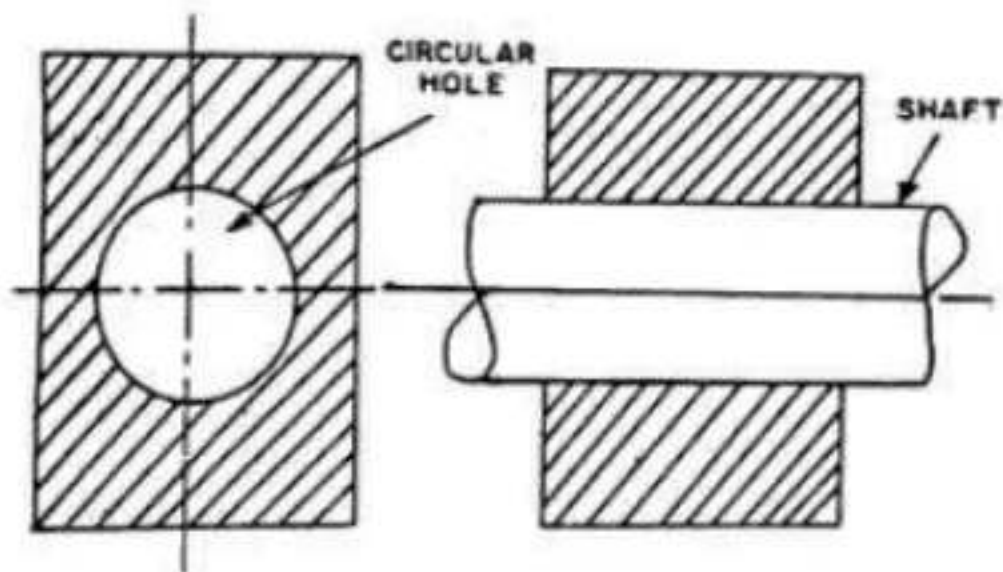

- Successfully Constrained motion

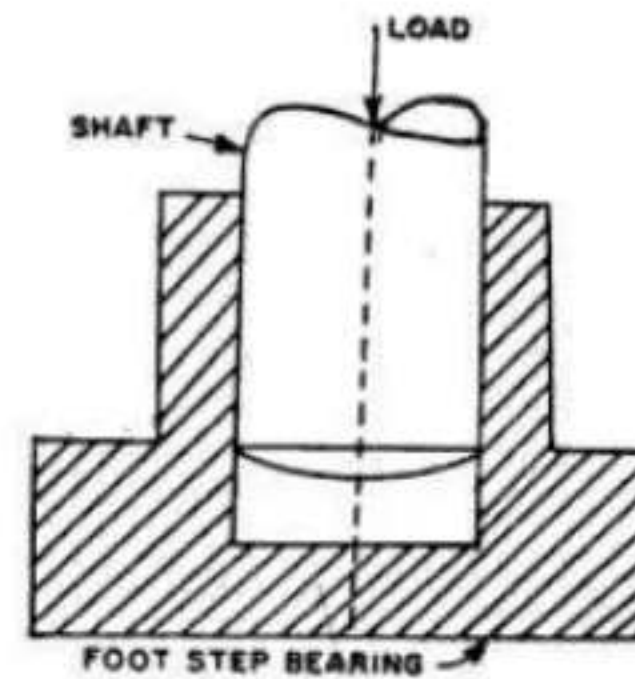

Completely Constrained Motion

When the motion between two elements of a pair is in definite direction, irrespective of the direction of force applied, then the motion is said to be completely constrained motion.

Shaft with Collar

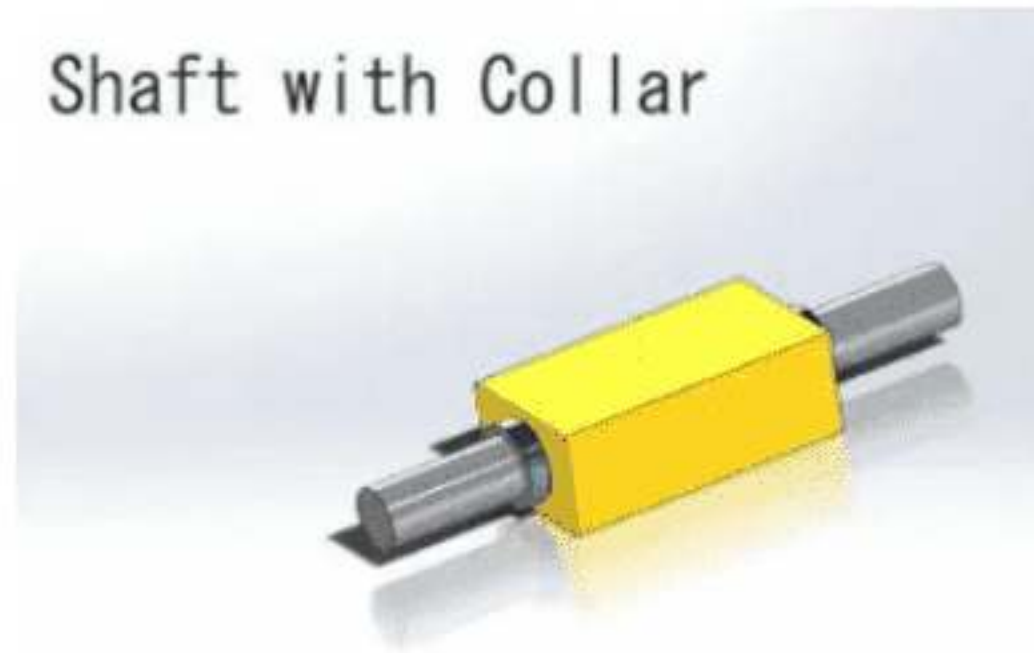

Square Bar in a Square Hole

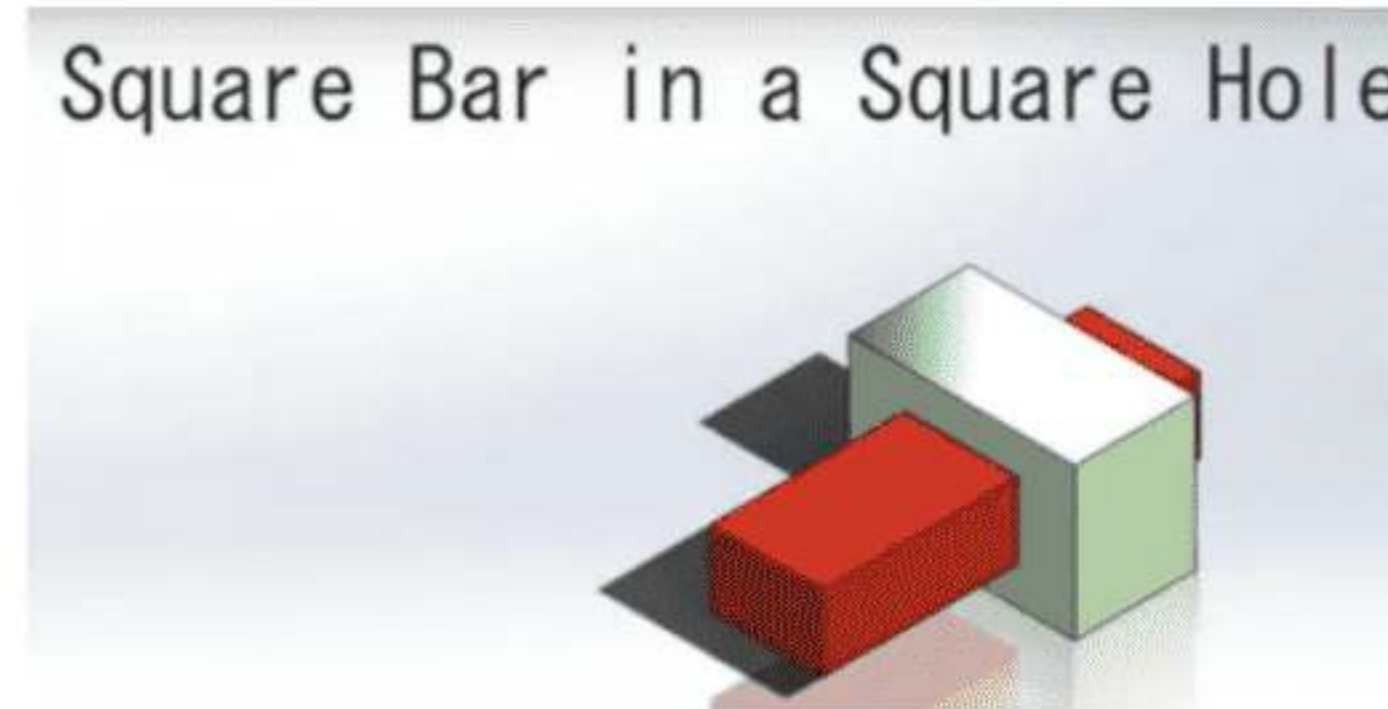

Incompletely Constrained Motion

When the motion between two element of a pair is more than one direction & depend upon direction of force applied, then the motion is said to be incompletely constrained motion.

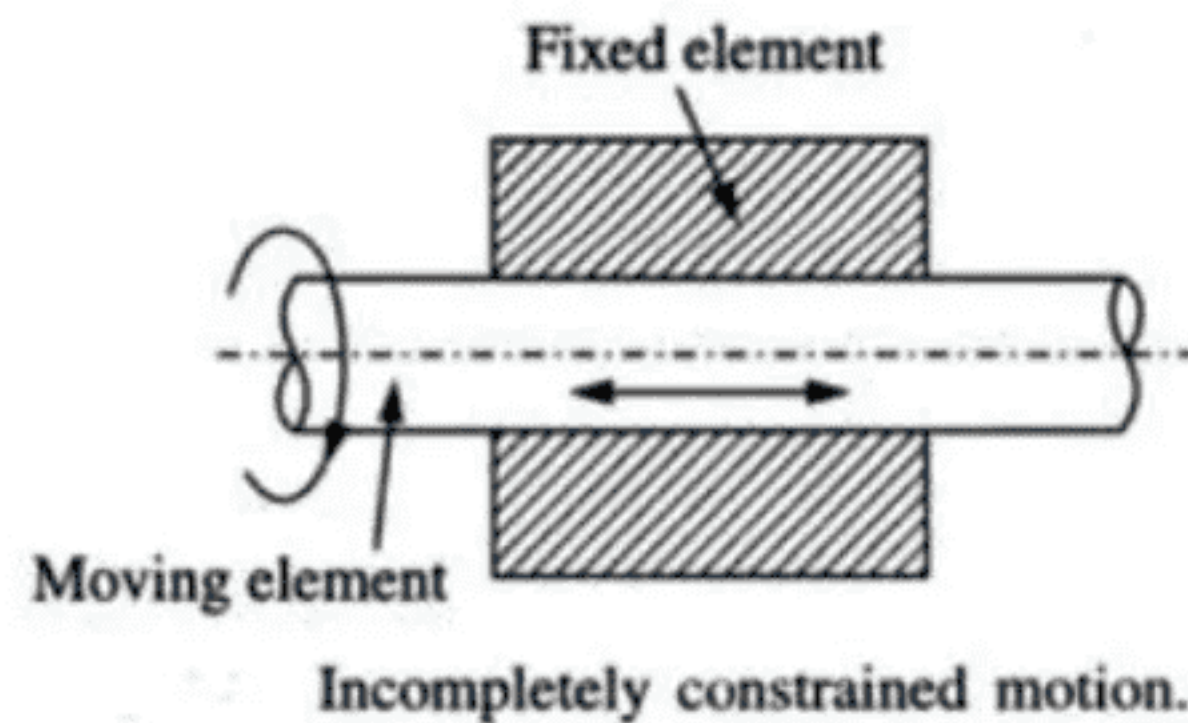

Successfully Constrained Motion

When the motion between two elements of a pair is more than one direction but it is made to have motion only in one direction by applying some external force, then the motion is said to be successfully constrained motion.

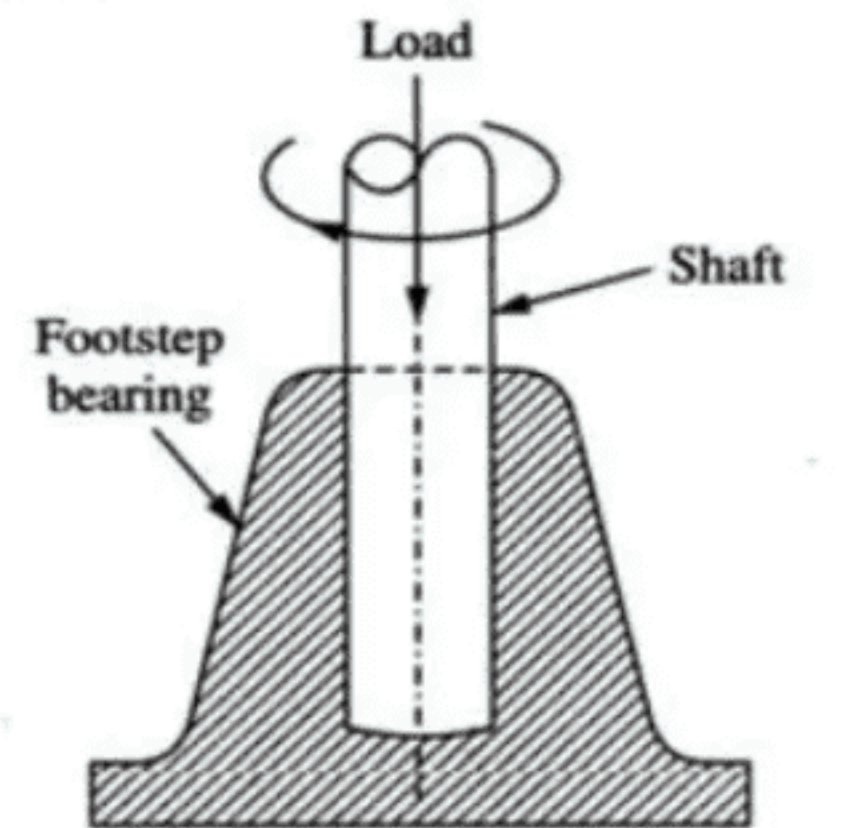

Partially constrained motion.

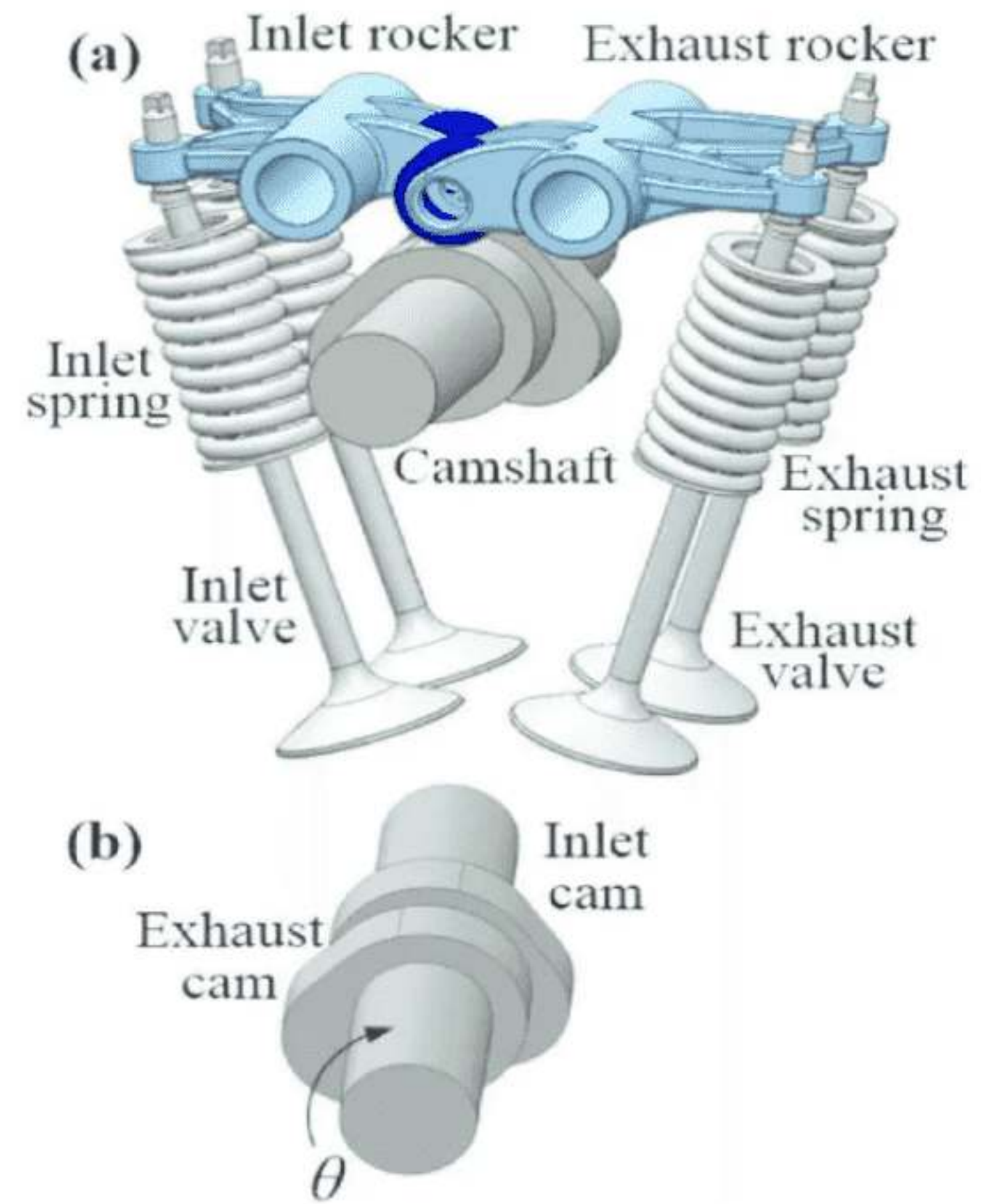
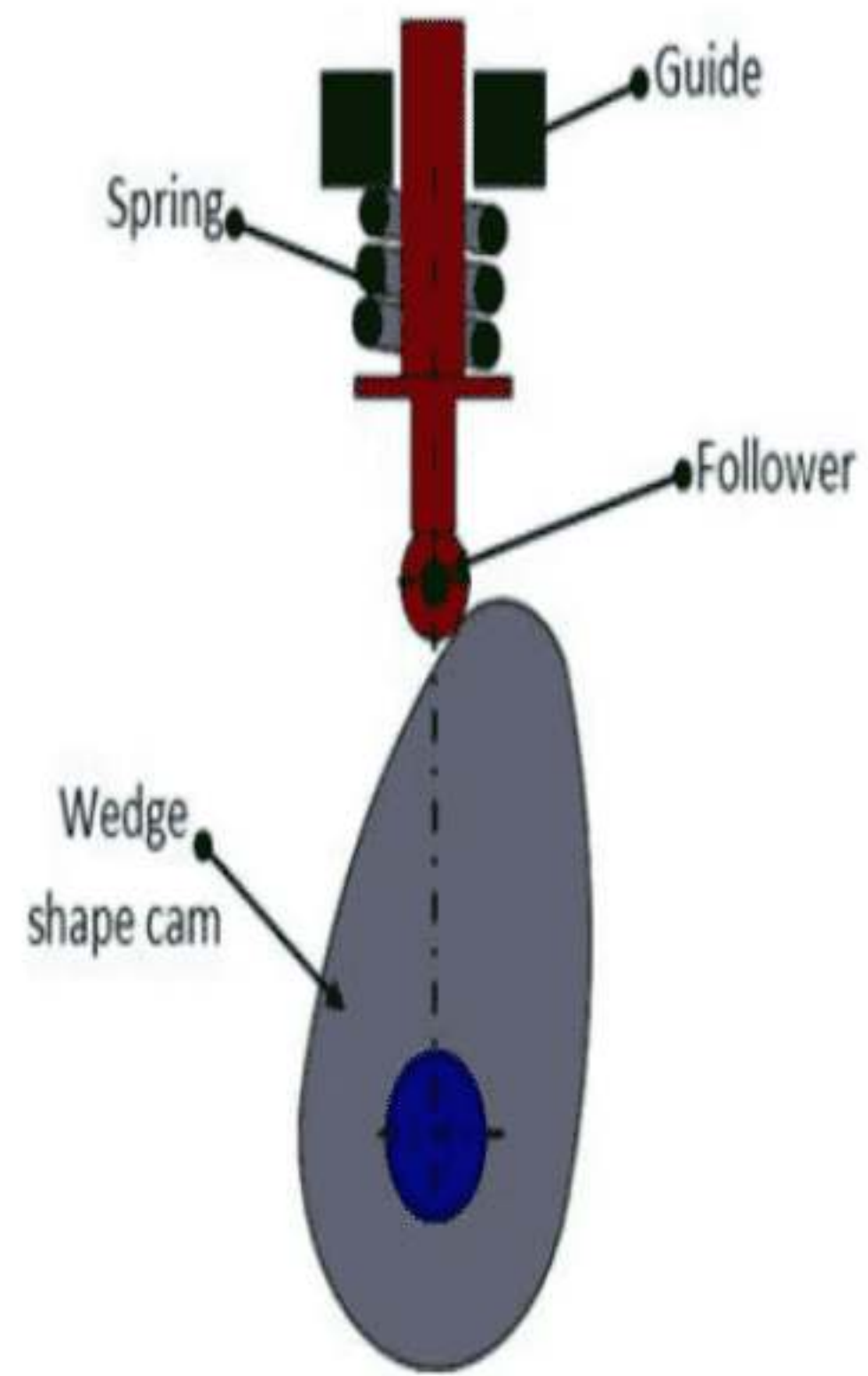



How to Get **Unacademy Plus** Subscription?

Step-by-Step Guide

Visit www.unacademy.com,
click on plus & choose your goal

Step 1

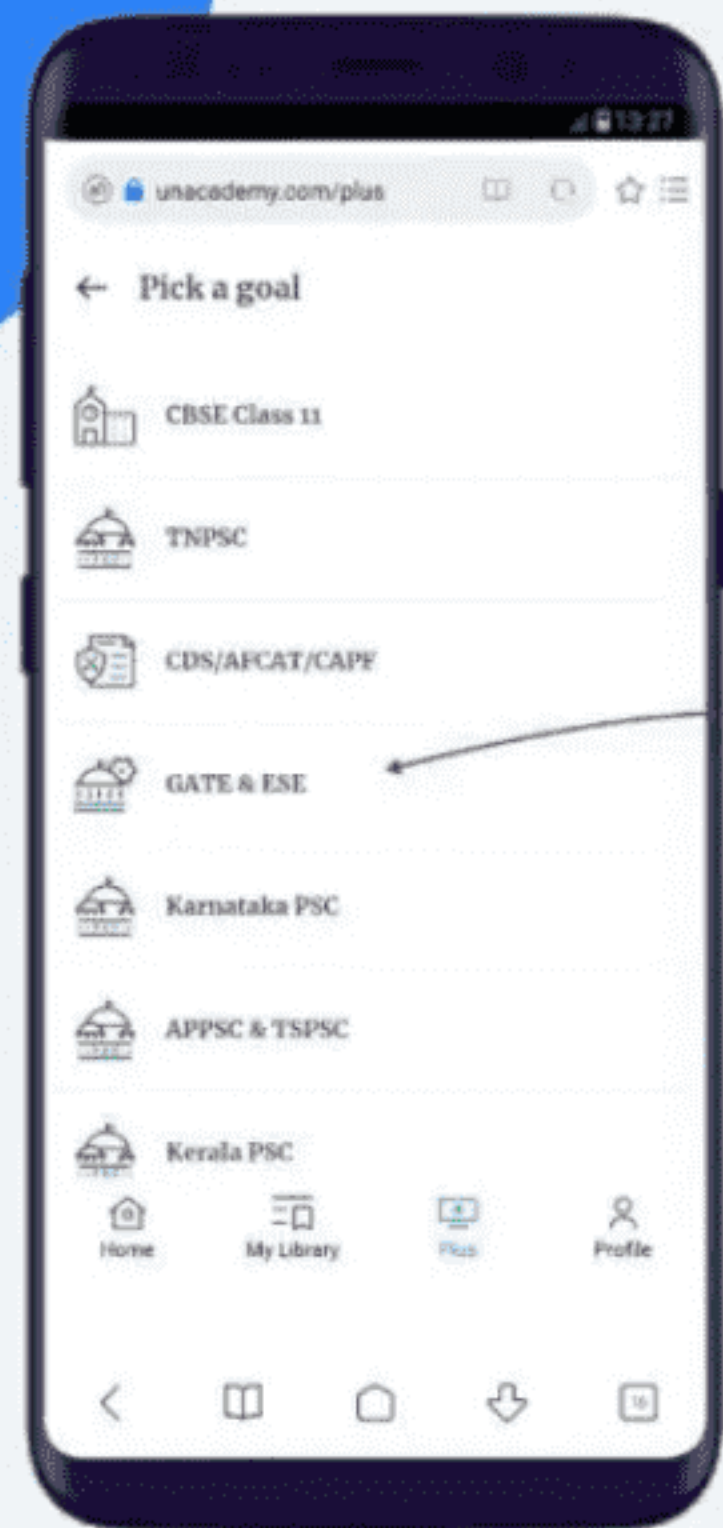

Scroll & click on
GATE & ESE

Step 2

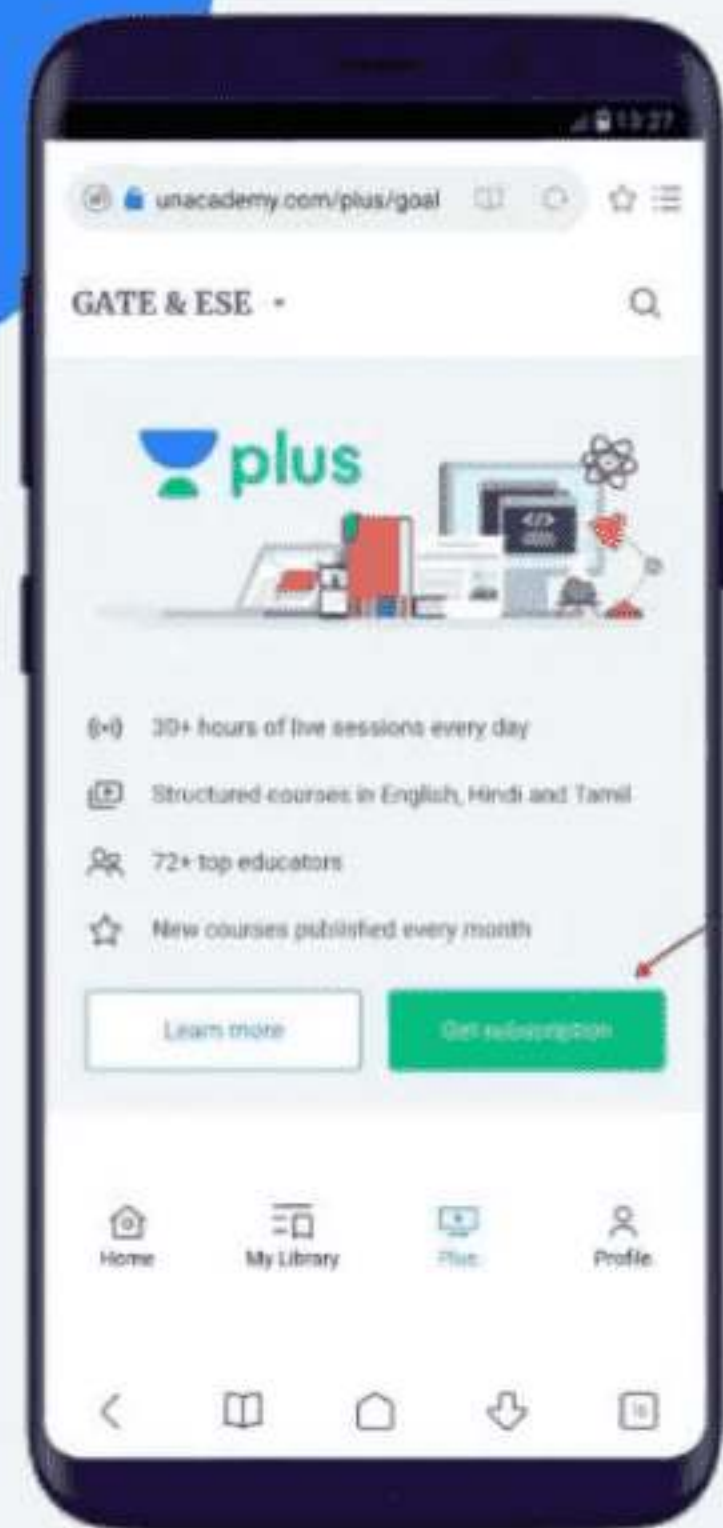

**Click on Get
Subscription Button**

Step 3

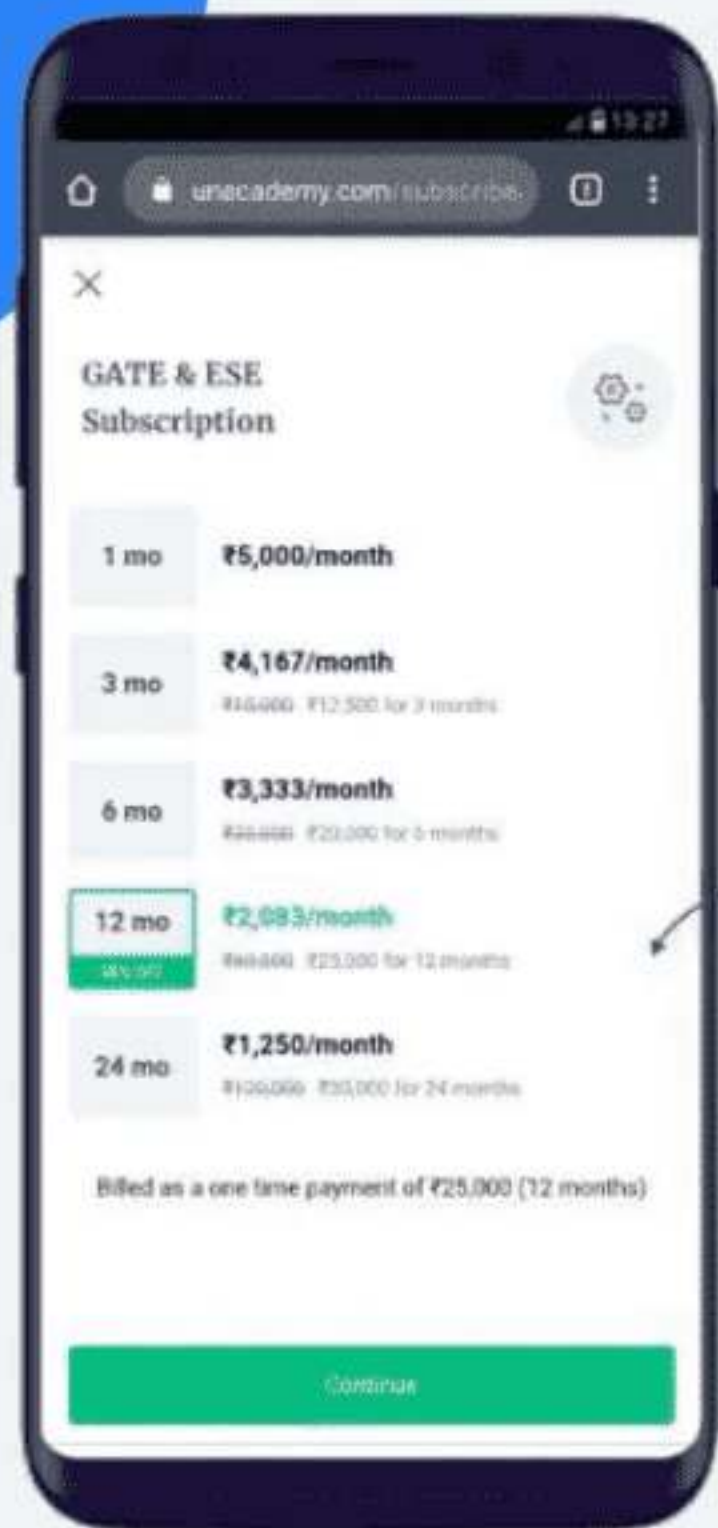

Choose the
Subscription you want

Step 4



**Apply my Coupon
Code **ALOKLIVE** &
Proceed to Pay**

Step 5

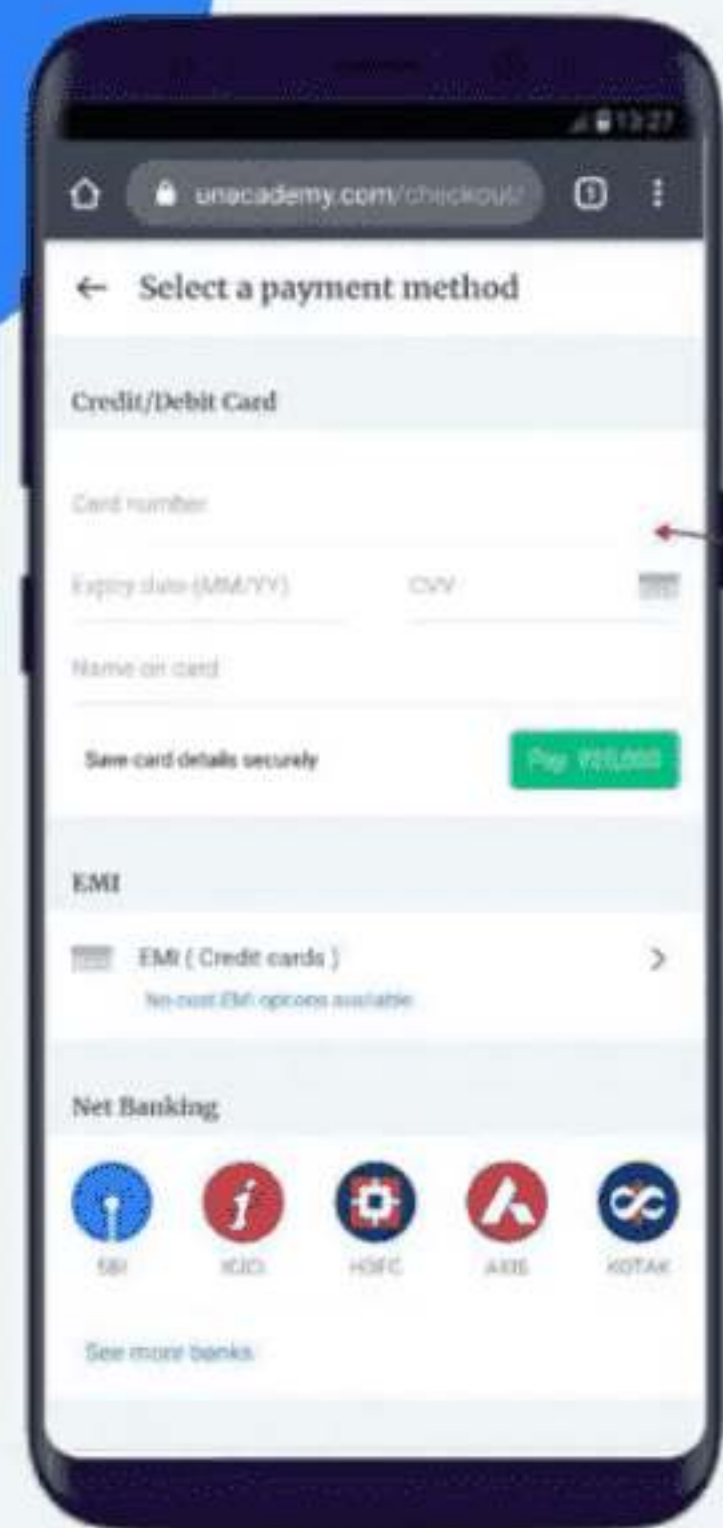

**Choose a Payment mode
& Enter your details.
Finally Click on Pay**

Step 6

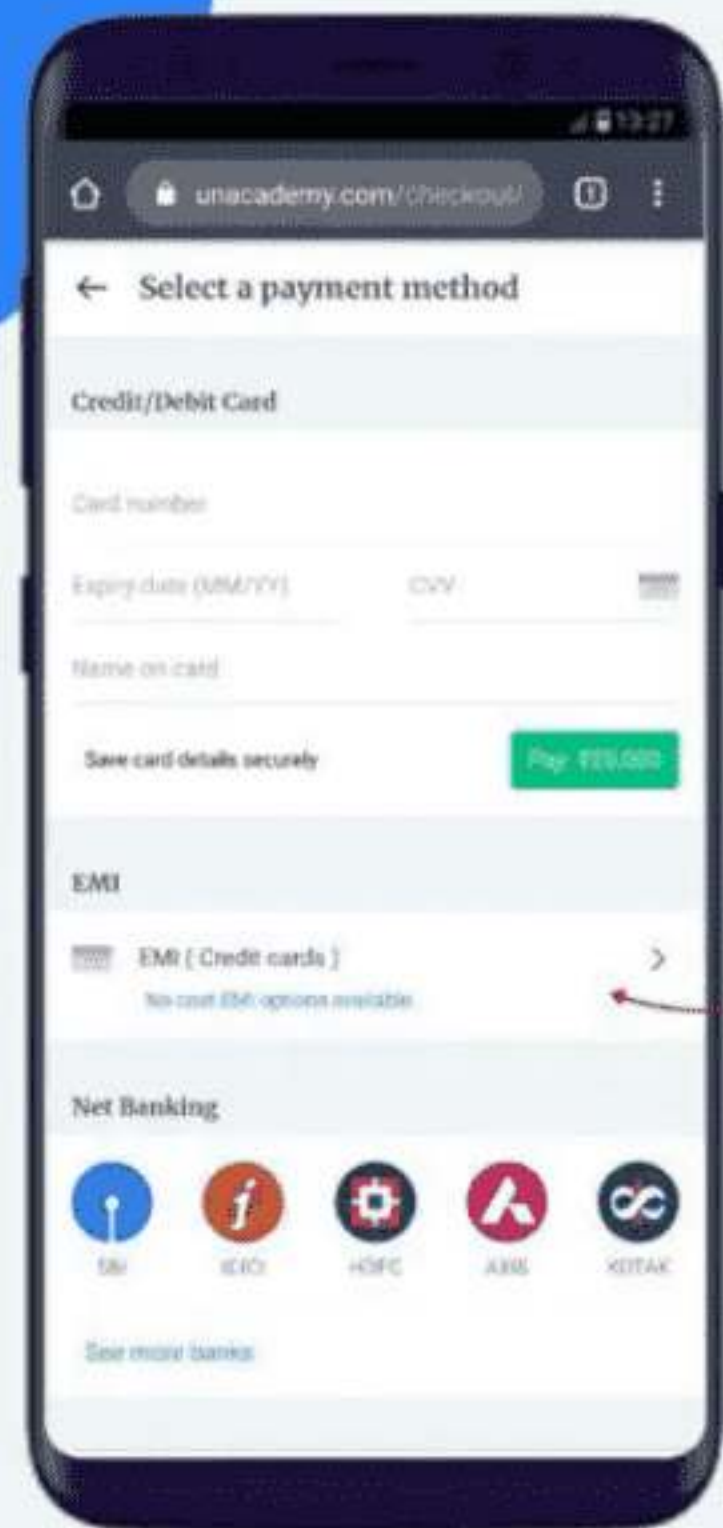

You can check
out various
EMI Options as well

Step 7



plus
Subscription



ALOK JHA SIR

GATE | ESE (ME)



4 Times

GATE Top Ranker
M.Tech IIT (ISM) Dhanbad



GATE/ESE:

8 Years Teaching
Experience



Subjects Taken:

Theory of Machines,
Strength of Materials,
Machine Design, and
Engineering Mechanics



Use My Referral

Code: **"ALOKLIVE"** to **Get 10% Off**
on Unacademy PLUS Subscription



UNACADEMY PLUS

LEARN ONLINE **LIVE** FROM
— INDIA'S BEST EDUCATORS —



Devendra Singh Negi



Pallav Gour



Sarvesh Srivastava



Alok Jha



Viresh Manocha



Apuroop Rao



Amit Dixit



Vishal Sharma

Syllabus

- Simple mechanism
- Velocity & Acceleration analysis
- Toothed gear
- Gear train
- Governor
- Flywheel
- Kinematic analysis of single slider crank chain mechanism
- Dynamics analysis of single slider crank chain mechanism
- Gyroscope
- Balancing of masses
- Vibration
- Cam & follower

Very Important topics in GATE

- **Simple machine (theory / numerical)**
- **Gear train (theory / numerical)**
- **Flywheel (numerical)**
- **Critical speed of shaft(vibration)**
- **Natural vibration (conceptual questions)**

GATE 2021 TOM SYLLABUS

Theory of Machines: Displacement, velocity and acceleration analysis of plane mechanisms; dynamic analysis of linkages; cams; gears and gear trains; flywheels and governors; balancing of reciprocating and rotating masses; gyroscope.

Vibrations: Free and forced vibration of single degree of freedom systems, effect of damping; vibration isolation; resonance; critical speeds of shafts.

- Books :-

- ✓ SS Rattan
- ✓ Thomas Bevan
- ✓ Joseph E. Shigley
- ✓ Class Notes

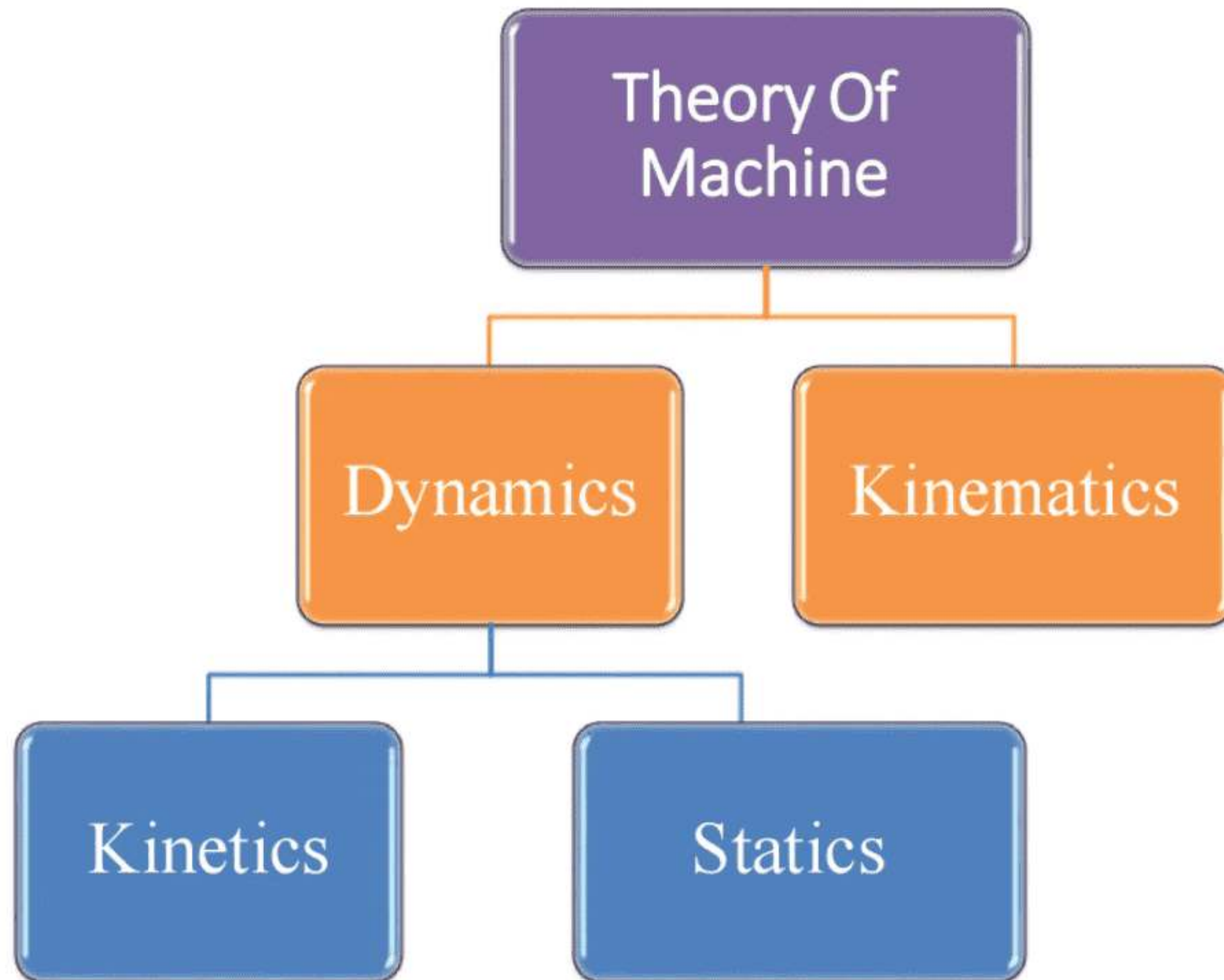

STATICS :

- It deals with the study the forces acting on machine in rest condition.

DYNAMICS :

- It deals with the study the forces acting on various parts of a machine or also we can say that study of motion with respect to force.

KINEMATICS :

- It is the study of motion, quite apart from the forces which produce that motion.
- Study of motion without considering force
- It is the study of position, displacement, rotation, speed, velocity and acceleration.

KINETICS :

- It is the study of inertia force which arises due to combined effect.

CHAPTER-1



SIMPLE MACHINE

SIMPLE MACHINE

□ WHAT IS MACHINE ?





Chatur Ramalingam : Sir, Machines are any combination of bodies so connected that their relative motions are constrained, and by which means force and motion may be transmitted and modified, as a screw and its nut, or a lever arranged to turn about a fulcrum or a pulley about its pivot. especially, a construction, more or less complex, consisting of a combination of moving parts or simple mechanical elements, as wheels, levers, cams etc.

Same thing, just in simple language ;



- **CHANCHAD:** “A machine is anything that reduces human effort. Anything that simplifies work, or saves time, is a machine. It's a warm day, press a button, get a blast of air - **the fan... A machine!** Speak to a friend miles away. **The telephone... A machine!** Compute millions in seconds. **The calculator... A machine!** We're surrounded by machines.

CONCLUSION OF THE STORY IS :-

- ✓ **Which reduce human effort.**
Example- Fan is a machine



Link
or
Part
or
Element

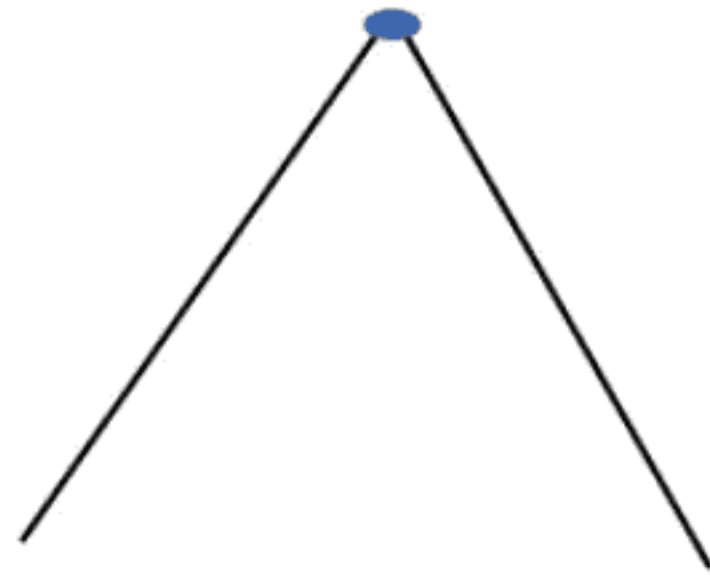

Pair

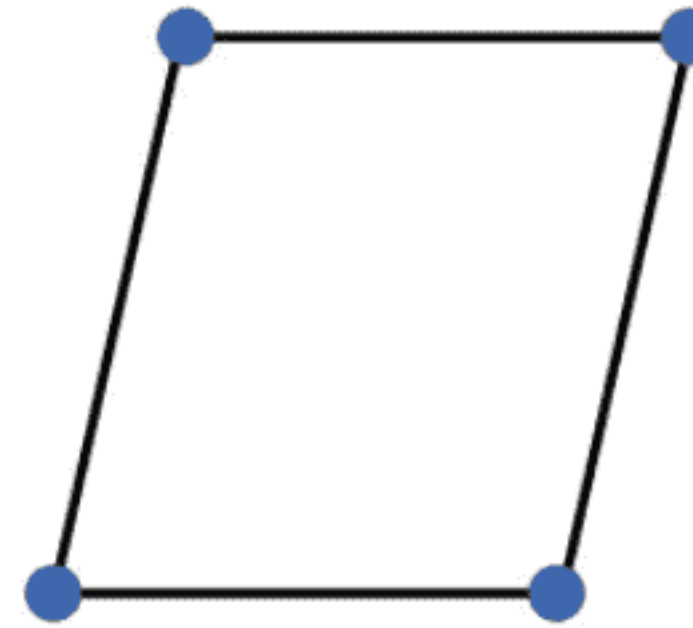

Chain

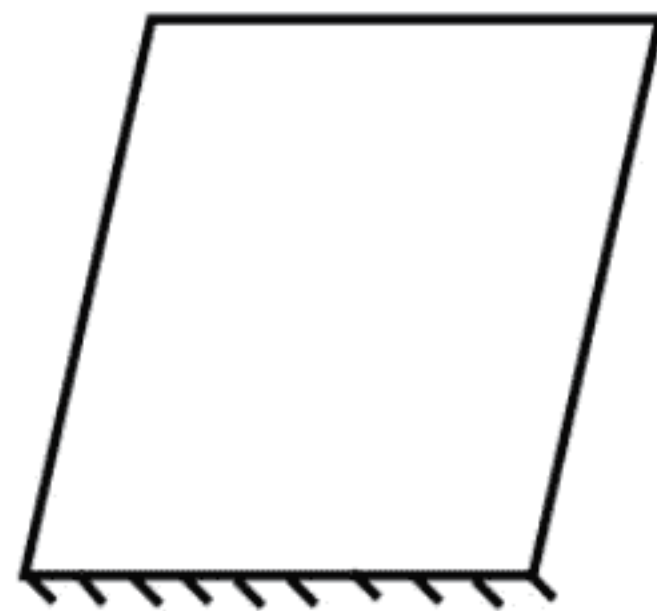

Mechanism

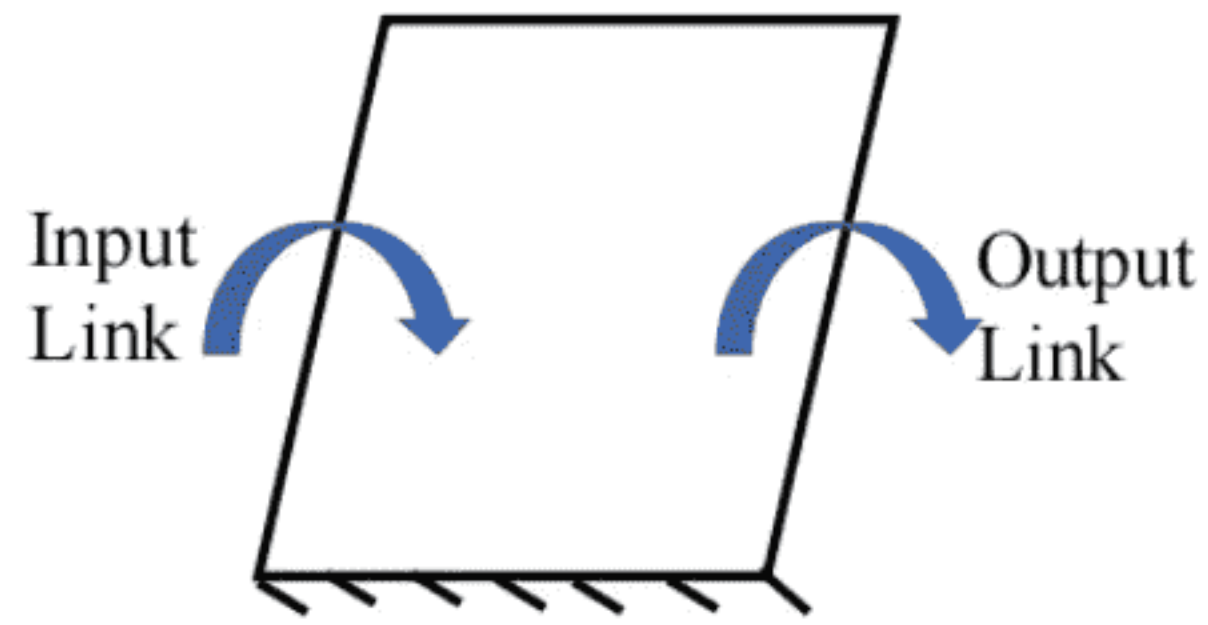

Machine

Now lets discuss about machine-

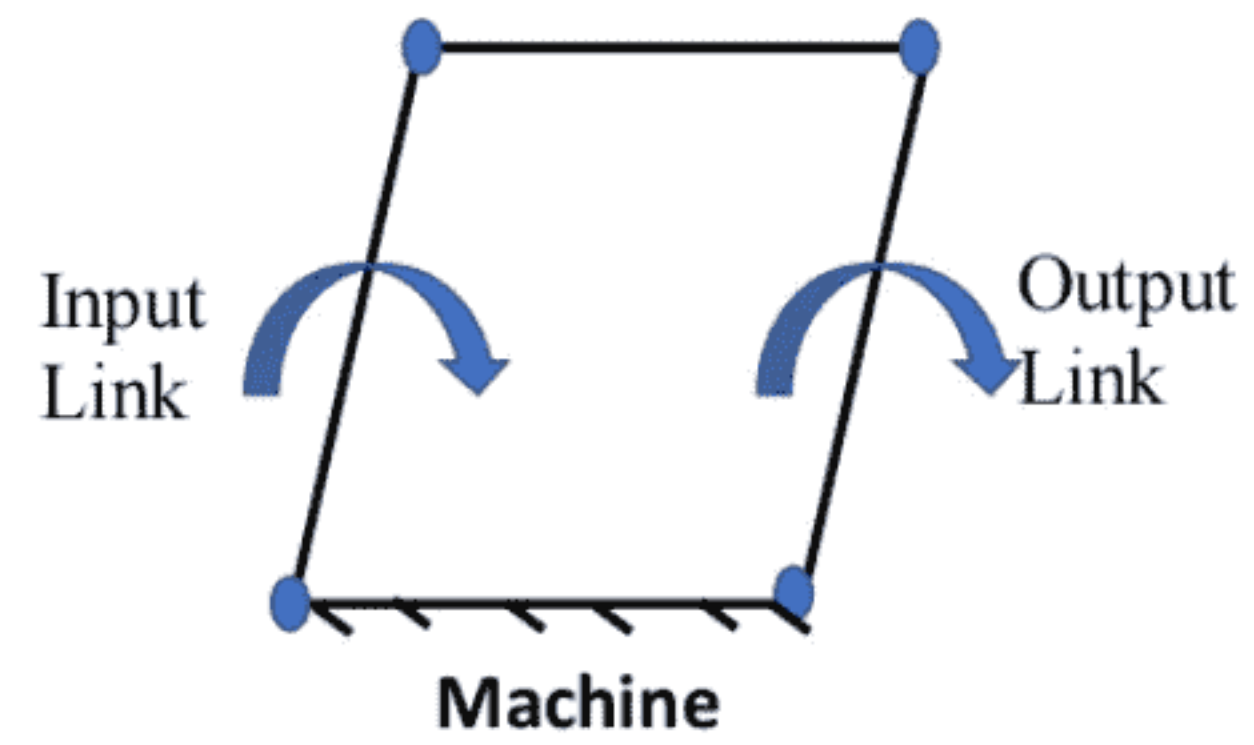

CONSTRAINED MOTIONS

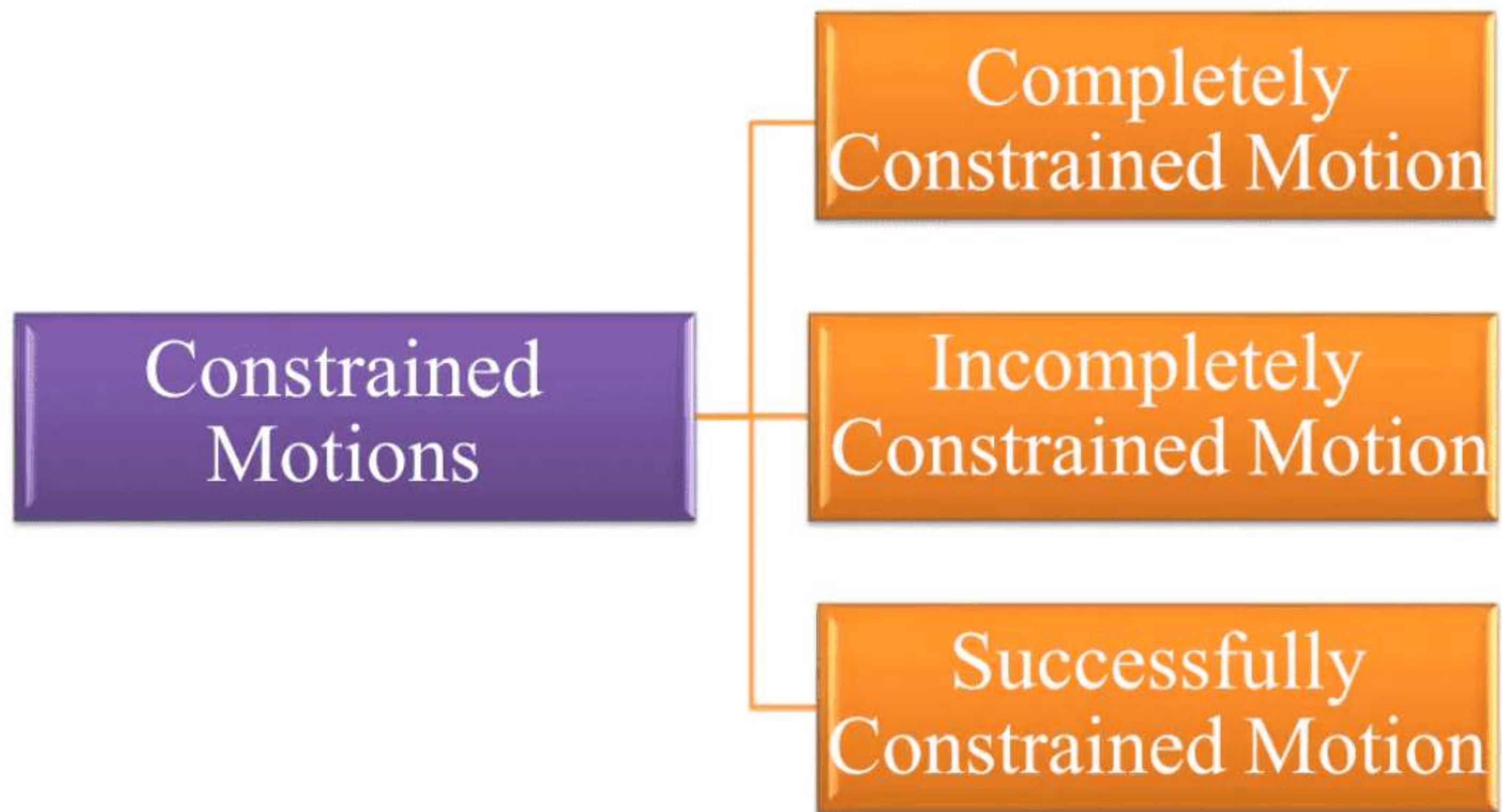

- Completely Constrained Motion

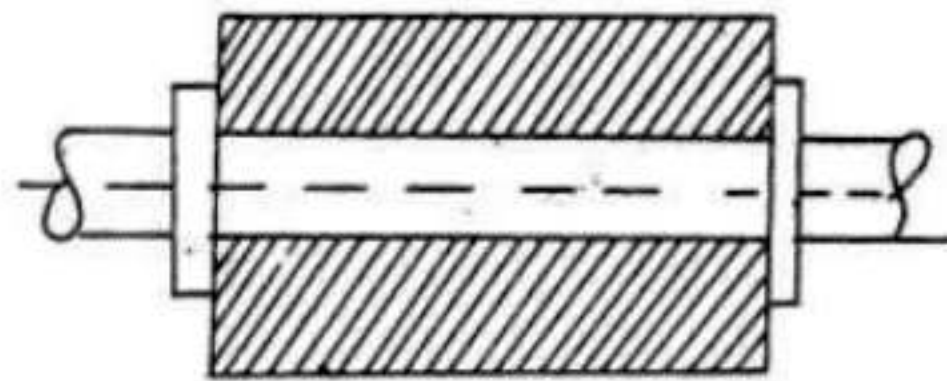
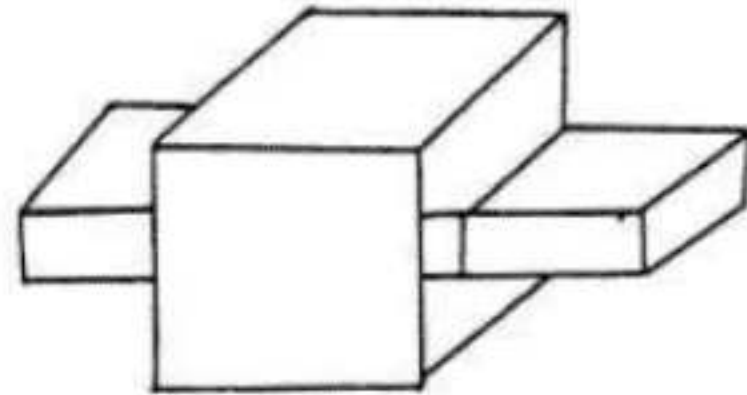

- Incomplete constrained motion

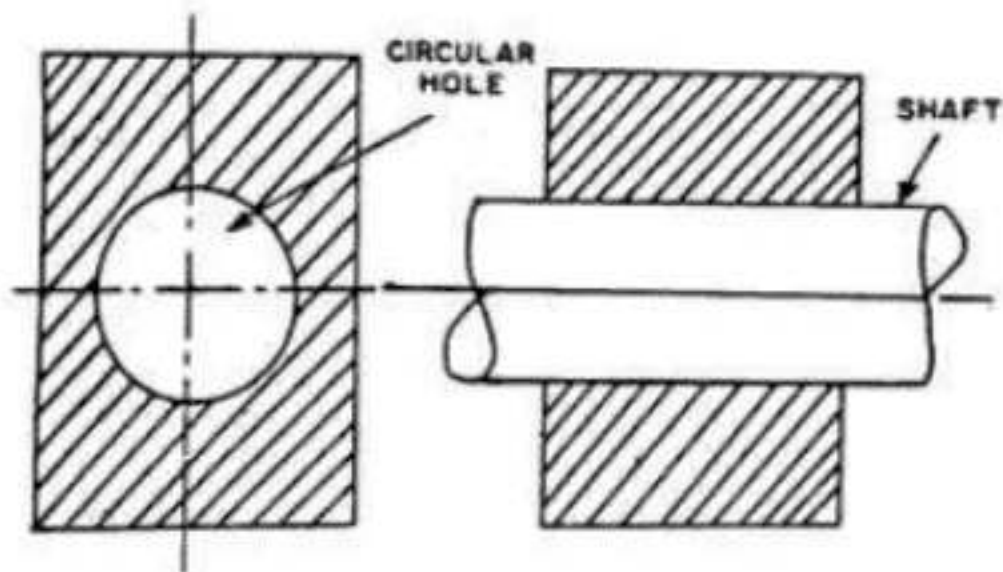

- Successfully Constrained motion

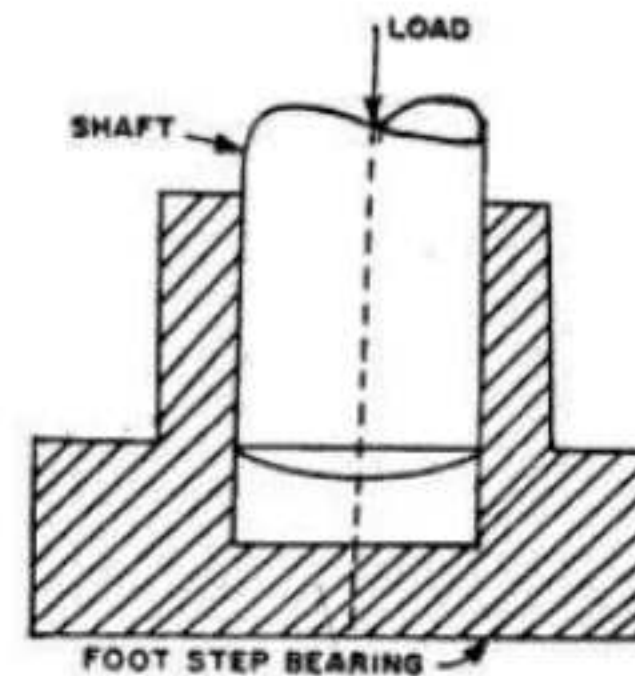

Completely Constrained Motion

When the motion between two element of a pair is in definite direction, irrespective of the direction of force applied, then the motion is said to be completely constrained motion.

Shaft with Collar

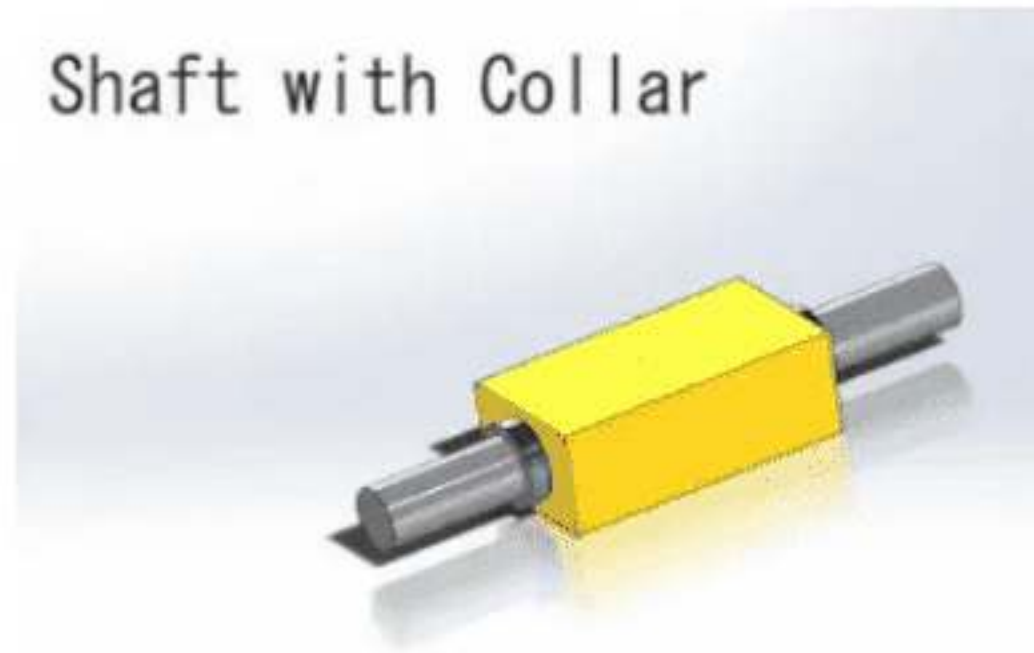

Square Bar in a Square Hole

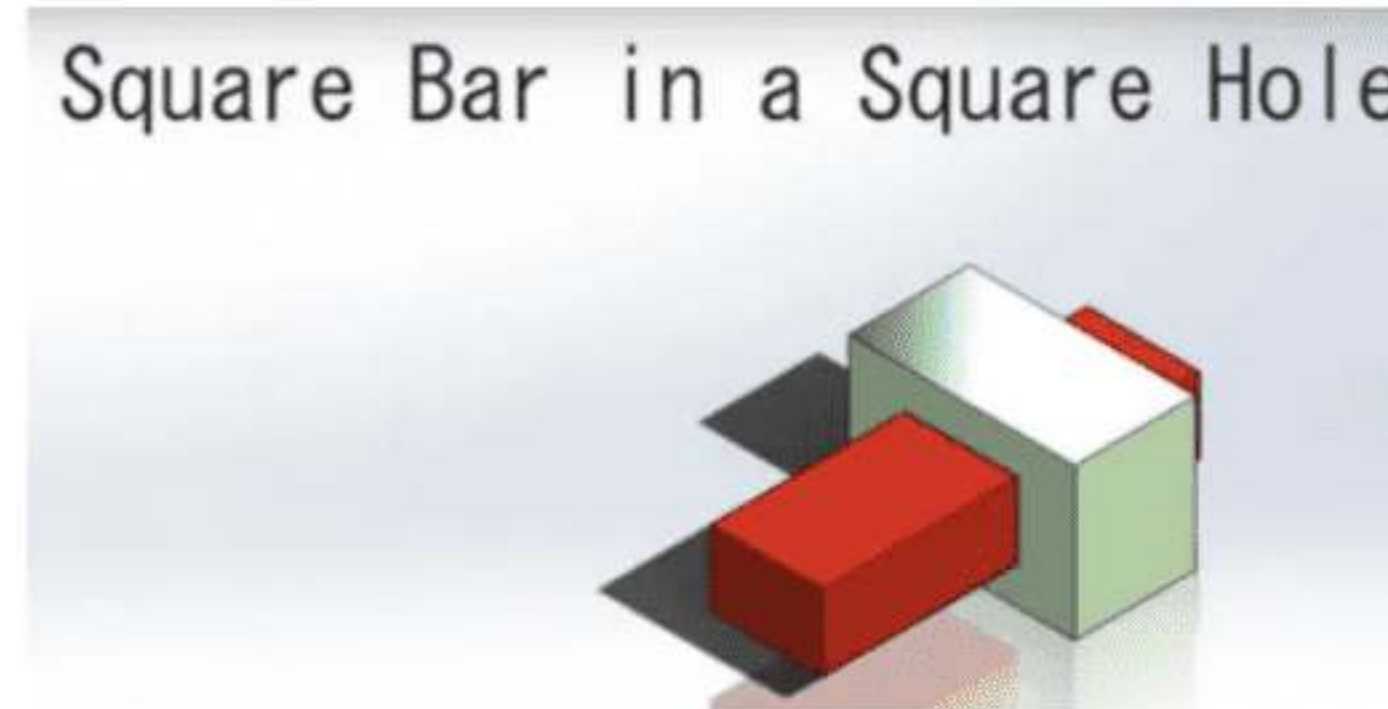

Incompletely Constrained Motion

When the motion between two elements of a pair is more than one direction & depends upon the direction of force applied, then the motion is said to be incompletely constrained motion.

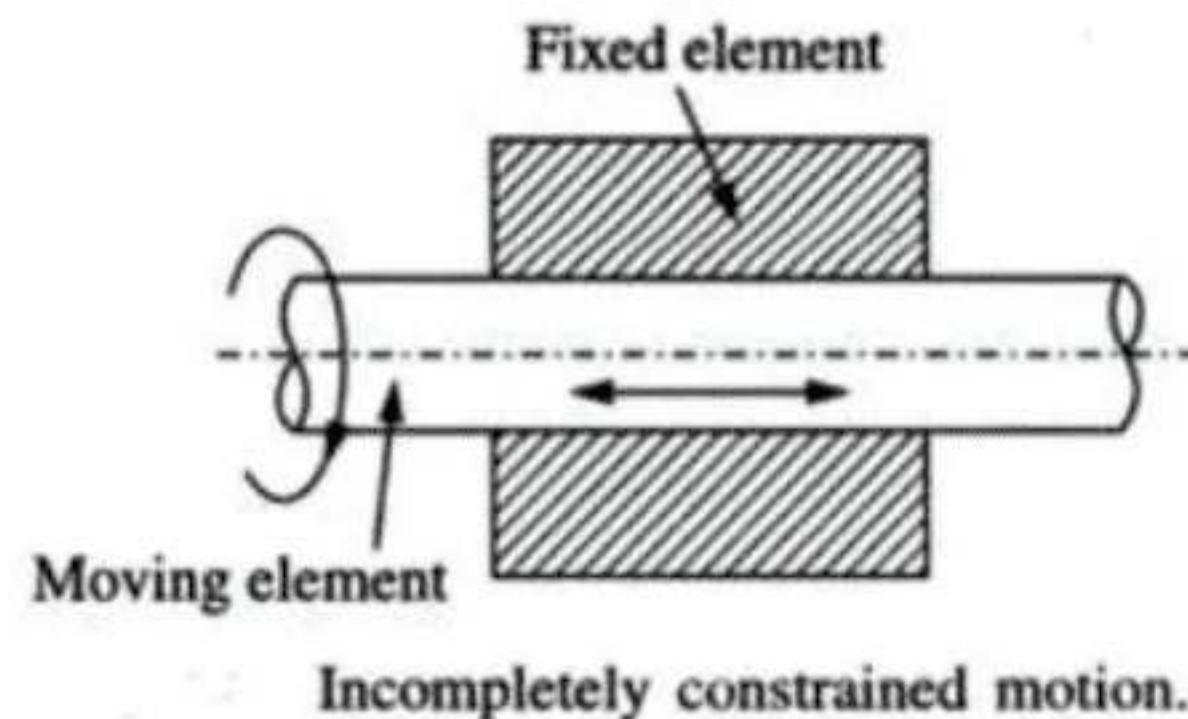

Successfully Constrained Motion

When the motion between two element of a pair is more then one direction but it made to have motion only in one direction by applying some external force, then the motion is said to be successfully constrained motion.

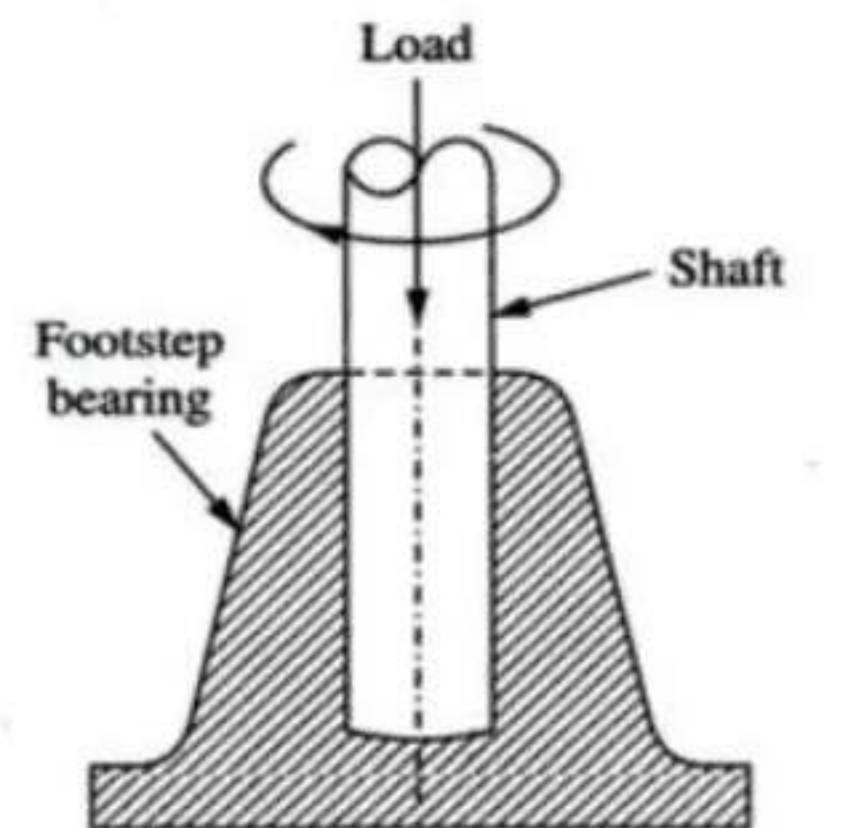

Partially constrained motion.

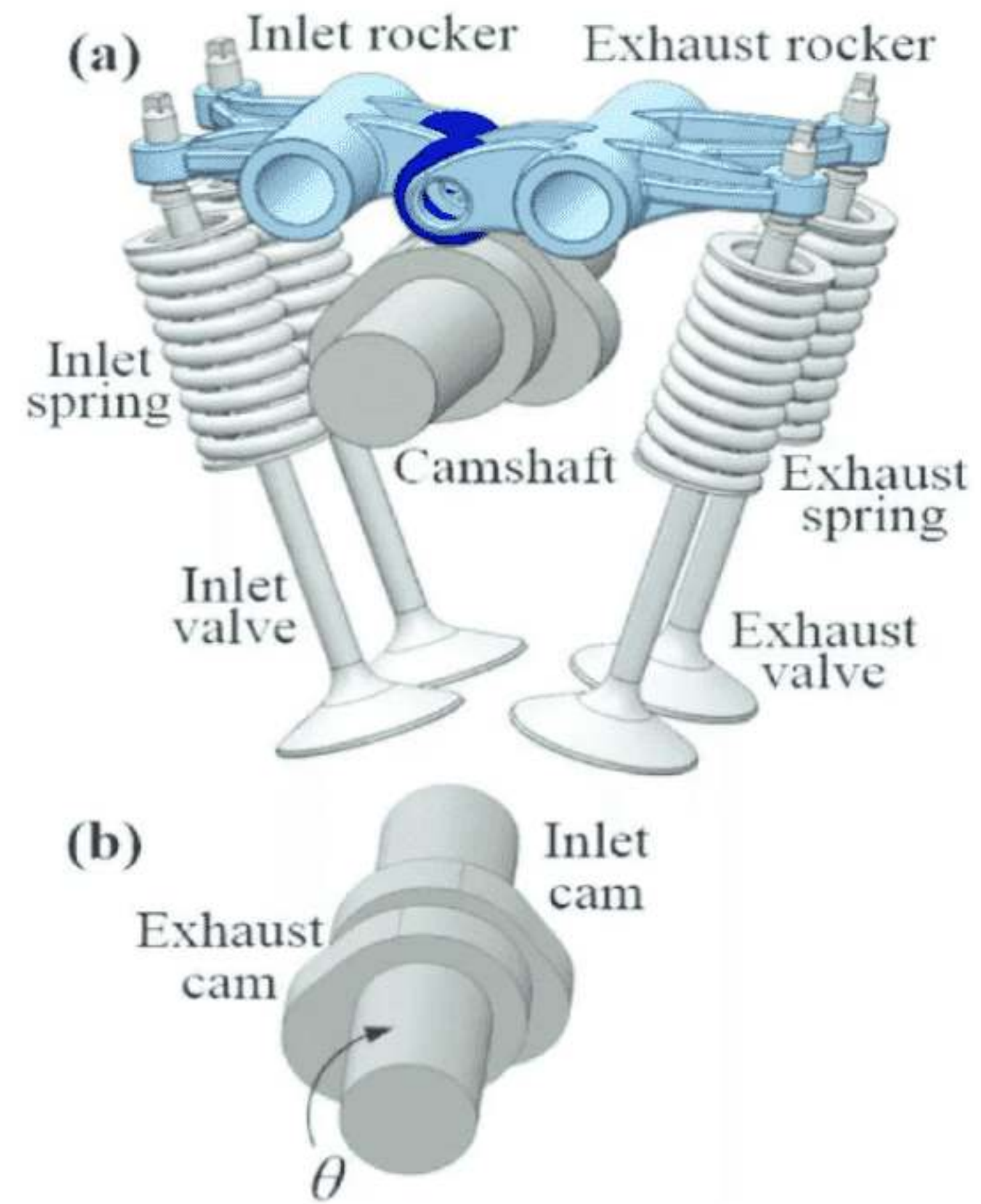
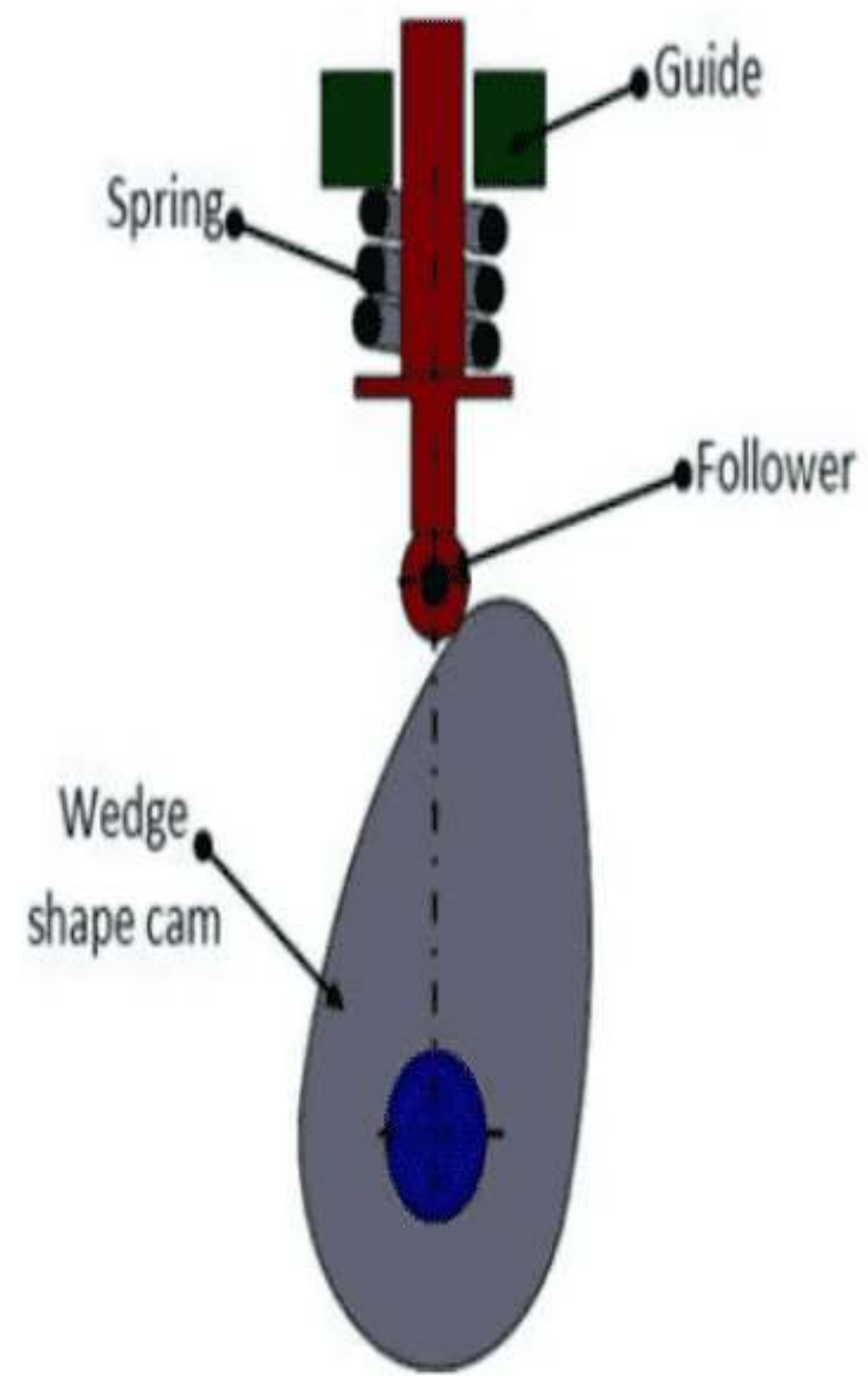

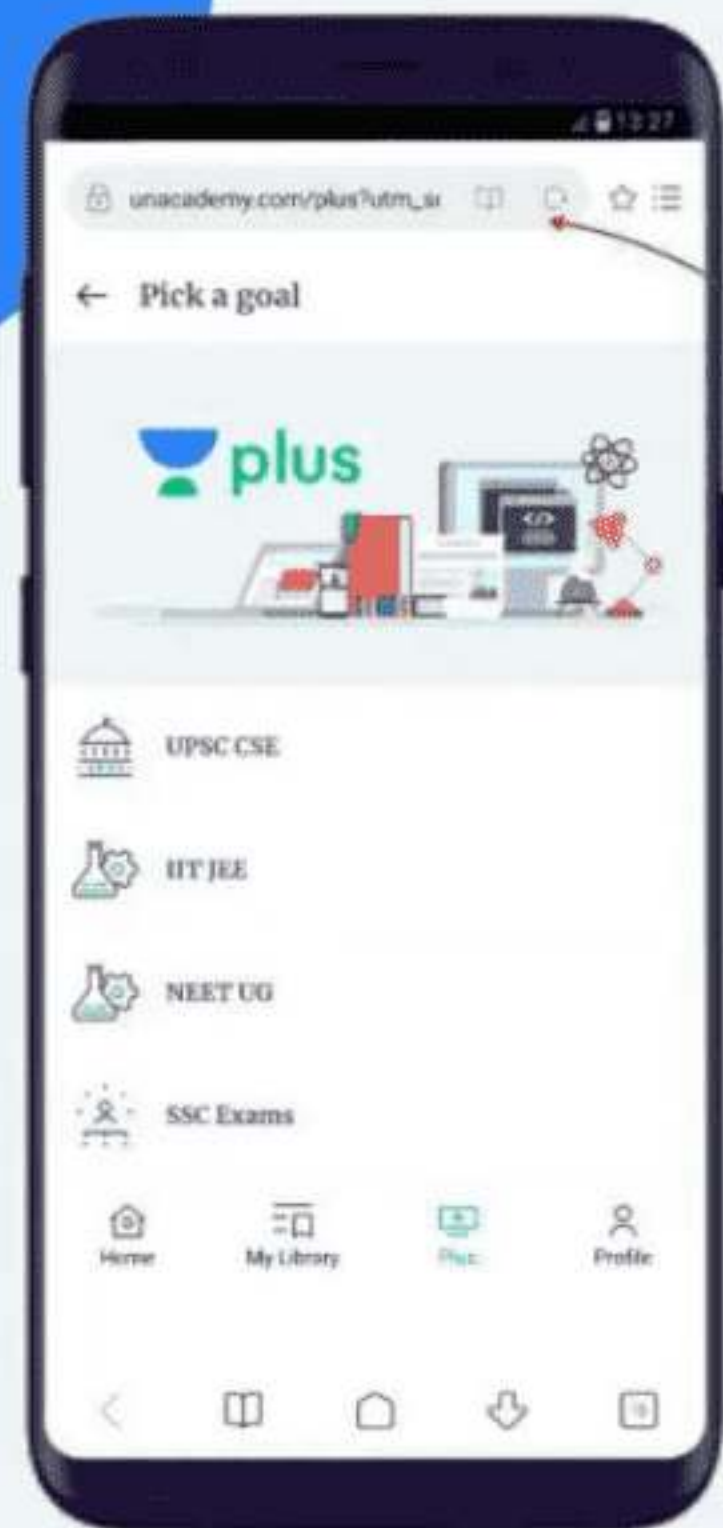

How to Get **Unacademy Plus** Subscription?

Step-by-Step Guide

Visit www.unacademy.com,
click on plus & choose your goal

Step 1

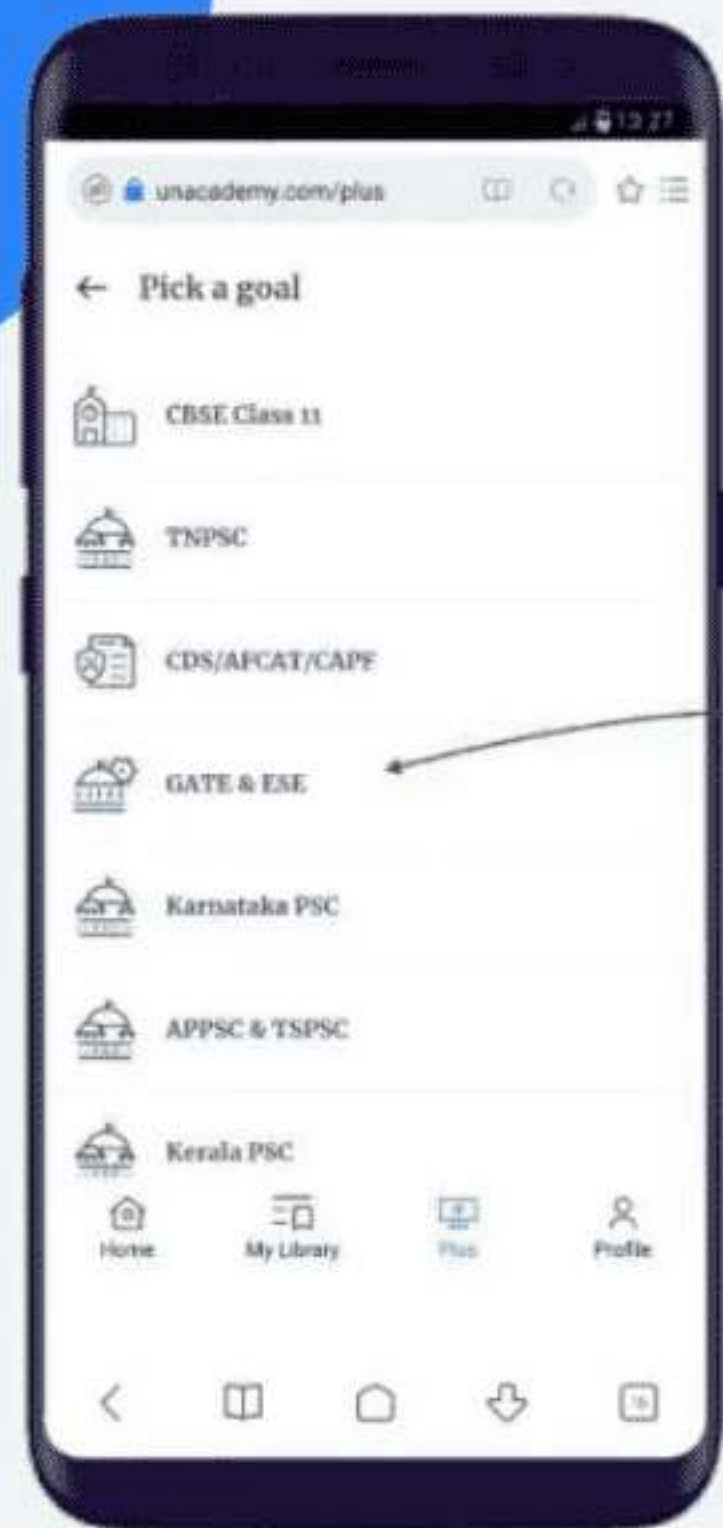

Scroll & click on
GATE & ESE

Step 2

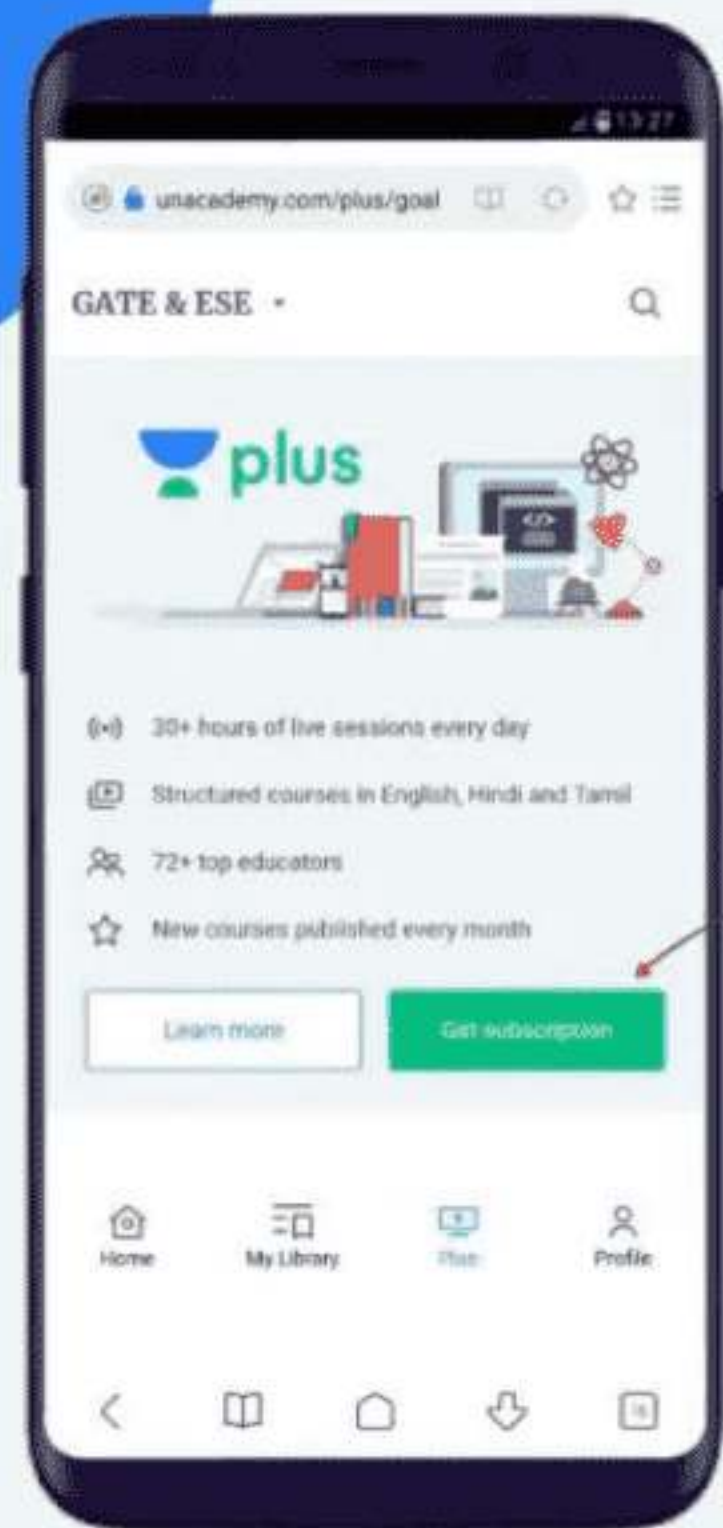

**Click on Get
Subscription Button**

Step 3

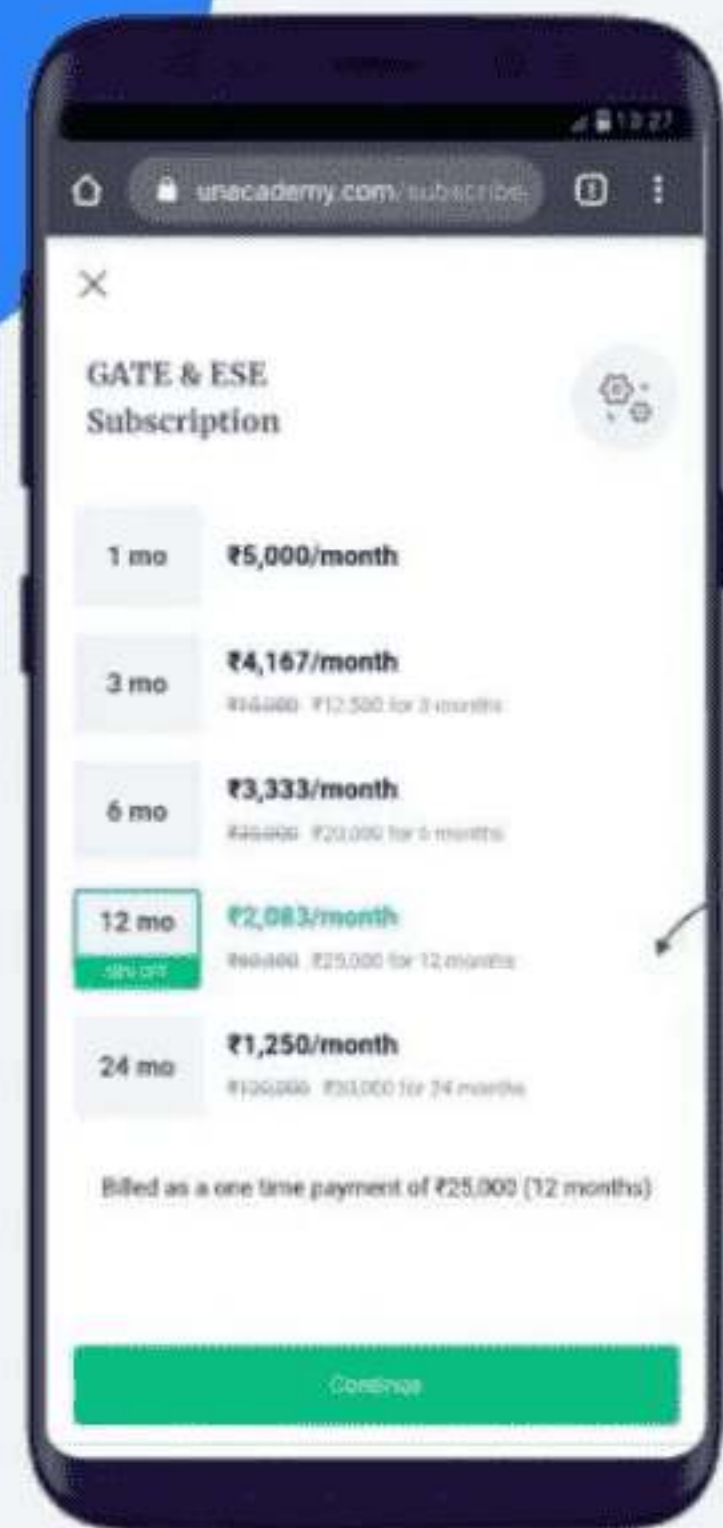

Choose the Subscription you want

Step 4



**Apply my Coupon
Code **ALOKLIVE** &
Proceed to Pay**

Step 5

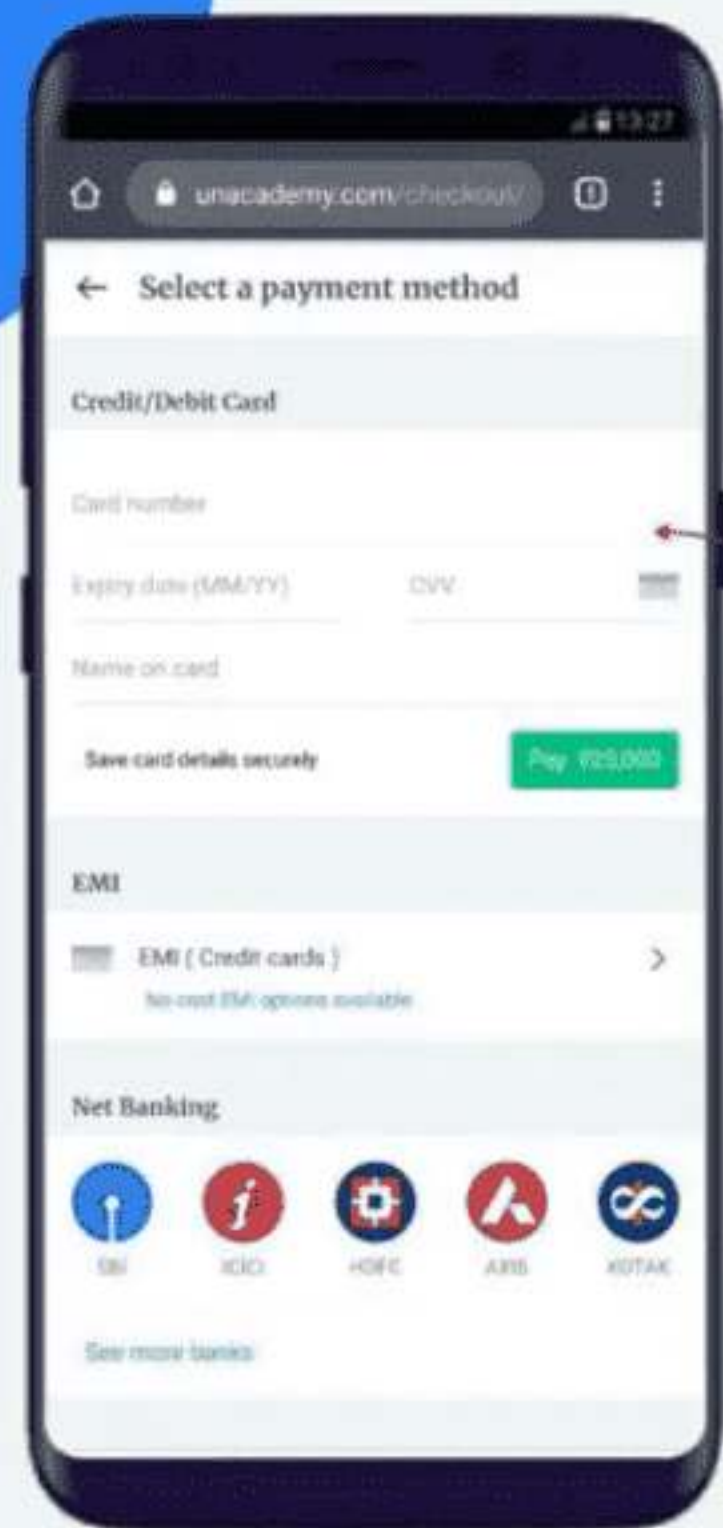

**Choose a Payment mode
& Enter your details.
Finally Click on Pay**

Step 6

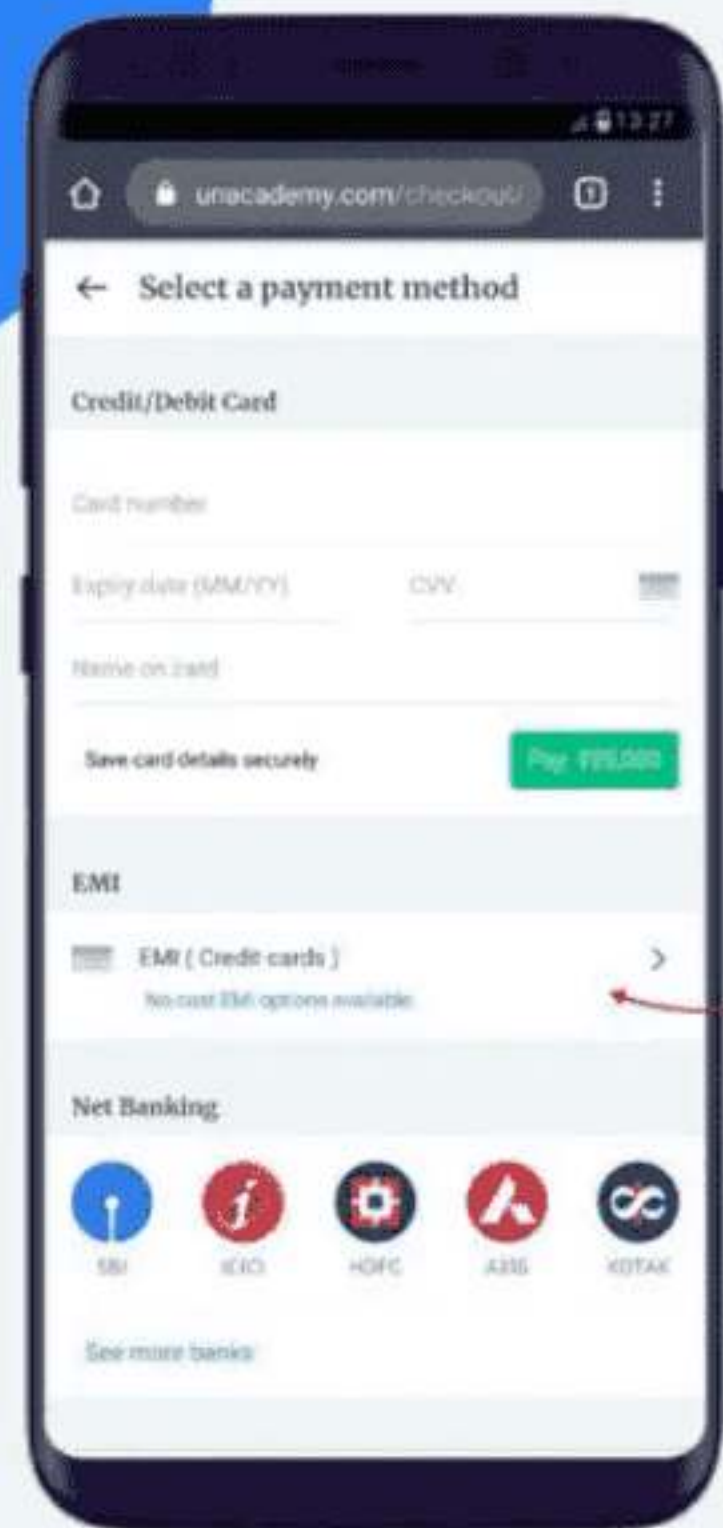

**You can check
out various
EMI Options as well**

Step 7